

"L" Shaped  
Leg  
Curtain w/track

"L" Shaped  
Leg  
Curtain w/track

Black Draw Curtain

Scrim (Flies)

Border  
Curtain (Flies)

2nd Elec

Open  
Pipe (Flies)

1st Elec

Border  
Curtain (Flies)

GP

Ground Plan

Production: Once Upon a Bridge

American Players  
Theatre 2023

Scale: 1/2" = 1'-0"

Date: 4/28/2023

Director: Laura Rook

Scenic Design: Lawrence Moten

TD: Bill Duwell.

ATD: Doug Dion

Notes:  
 +Legs probably shouldn't be glued until the facing walls are attached and its all set up to make sure the rake is all on the same plane.  
 +Platforms A & B are composed entirely of wood, much of their components have already been cut out by a CNC machine.  
 +Platform C is made like our normal 2" decks and has also had its components cut out as well.  
 +Platform A & B have rakes. Platform B has its rake axis aligned with the long edge of the ellipse geometry. Platform A's rake axis is 22 degrees off of the ellipse centerlines. Platform A is broken along its rake axis lines instead of on the ellipse geometry lines.

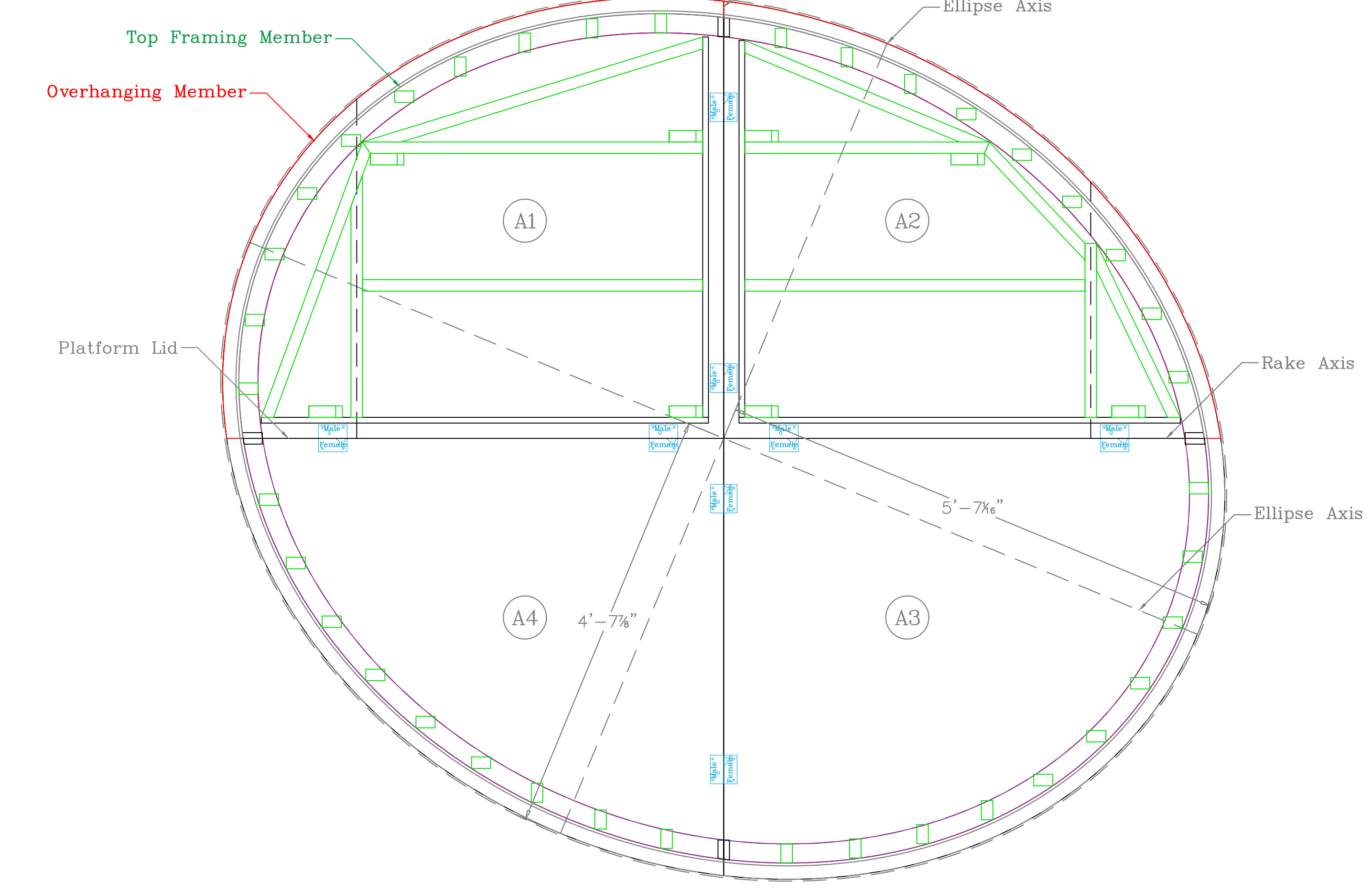
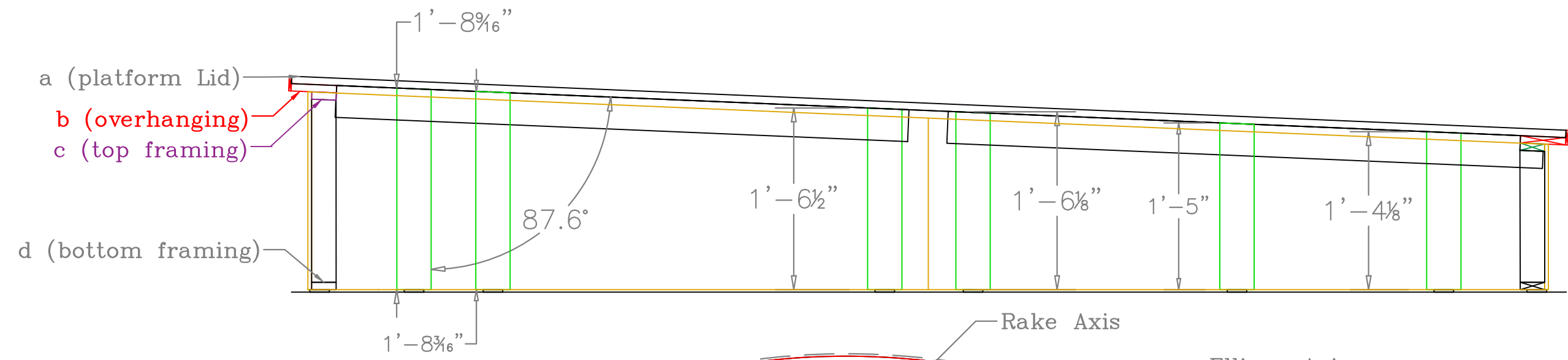
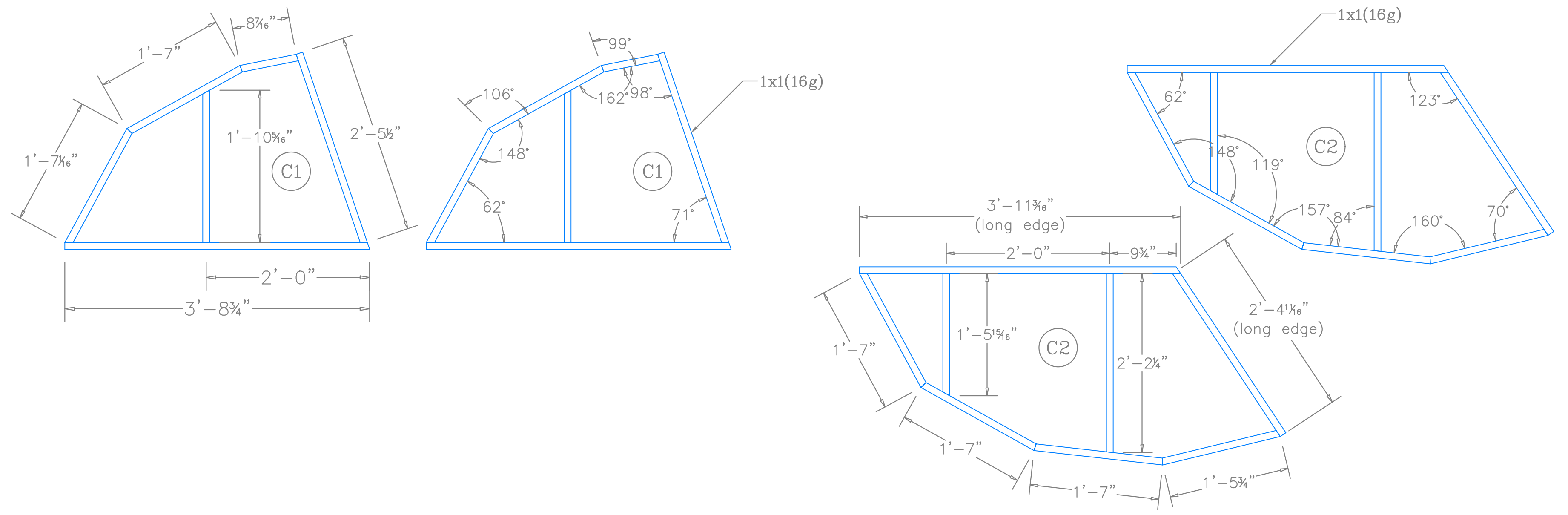

1 Ellipse A Overview - Aligned View  
 1" = 1'-0"

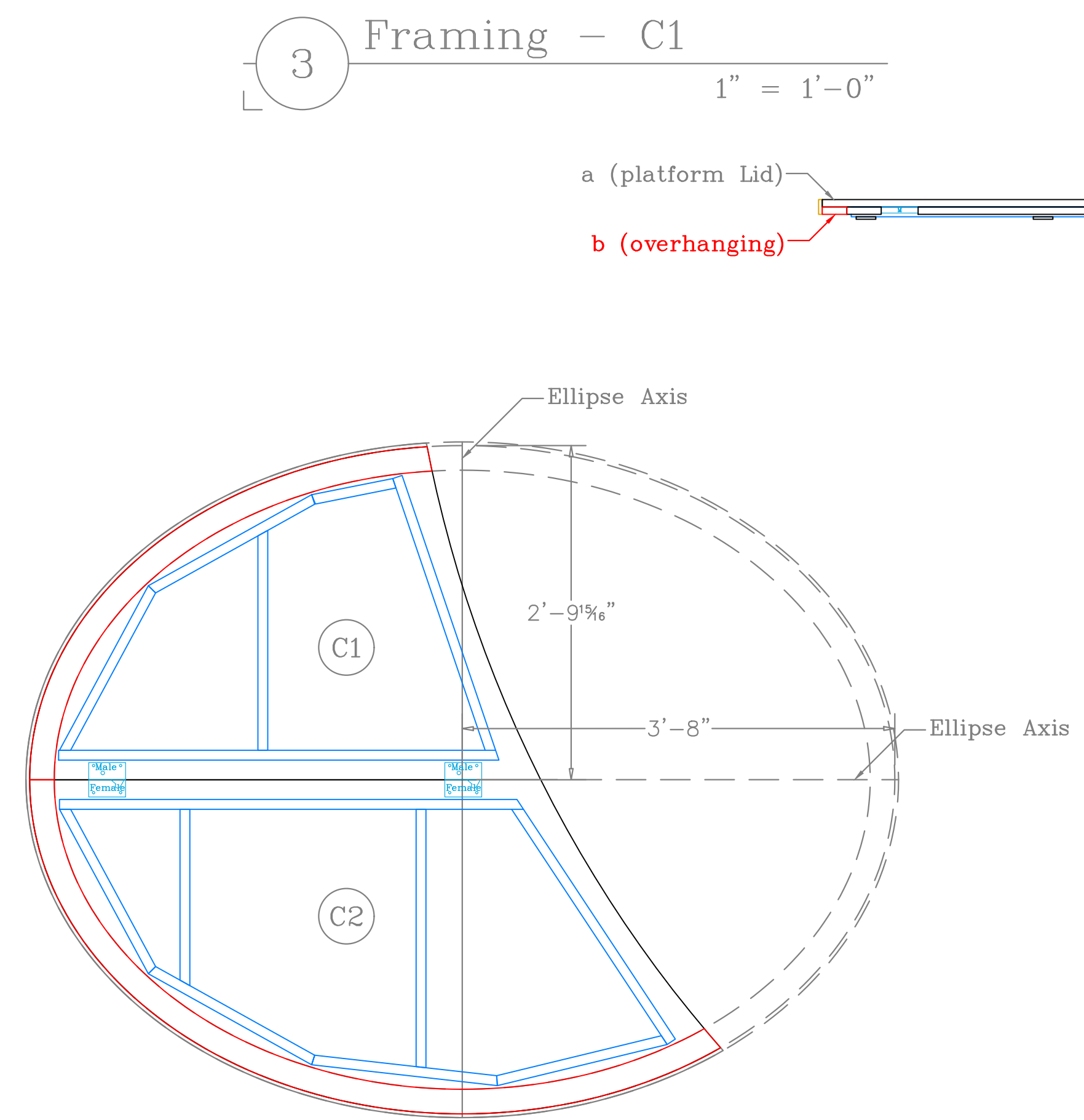

2 Ellipse C - Overview  
 1" = 1'-0"

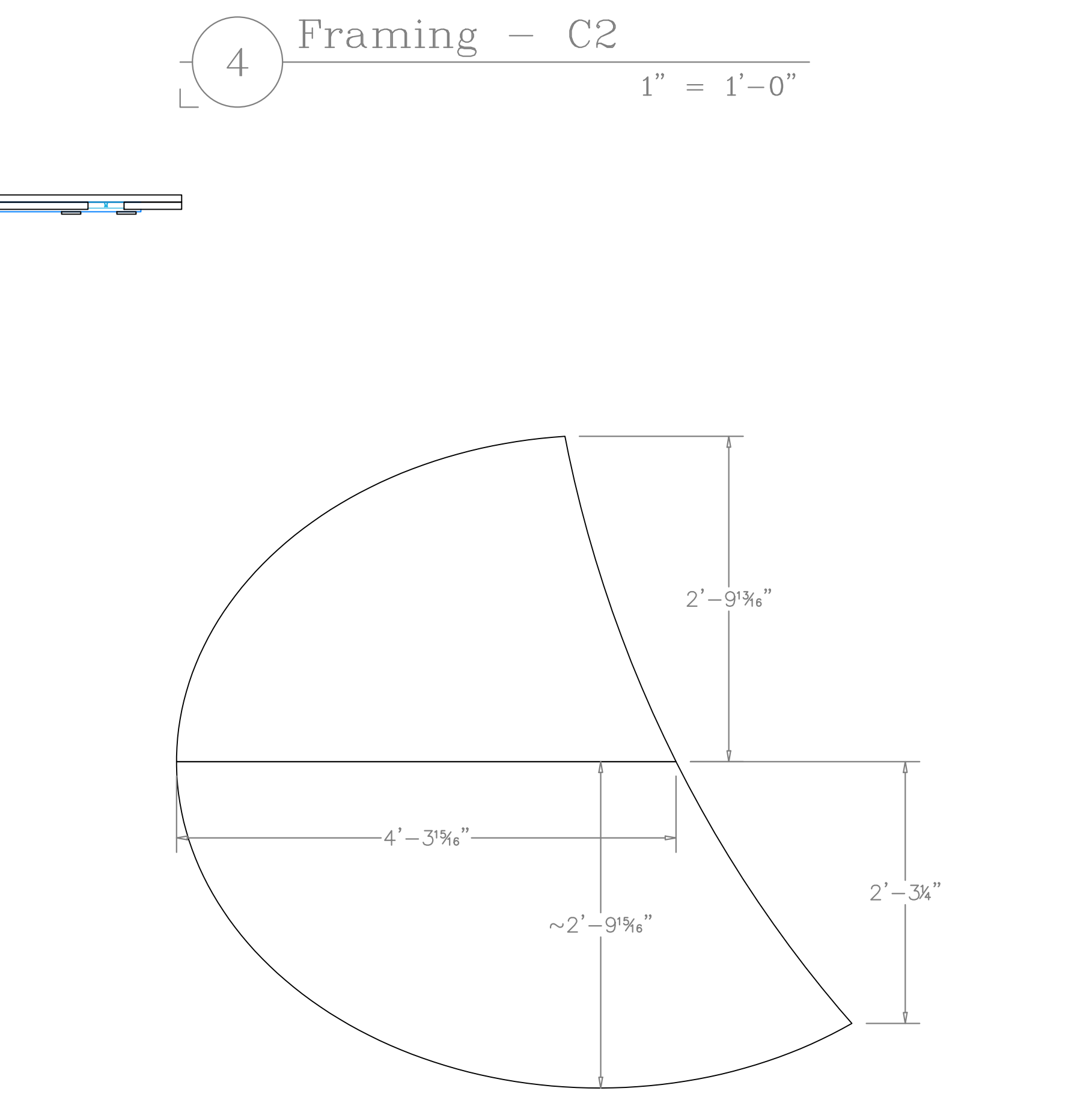

3 +2" Deck Lids  
 1" = 1'-0"

3 Framing - C1  
 1" = 1'-0"

4 Framing - C2  
 1" = 1'-0"

1	Ellipse A & C - Framing - Aligned View	American Players Theatre 2023	Scale: 1" = 1'-0"	Director: Laura Rook	TD: Bill Duwell.
	Production: Once Upon a Bridge		Date: 4/28/2023	Scenic Design: Lawrence Moten	ATD: Doug Dion

Notes:  
 +Plates 1, 2, 3 & 5 show how these plywood pieces will be used, but aren't critical to the cutting of them.  
 +Plate 4 & 5 show all the sheets that need to be CNC cut. 'X's here indicate which side of the lines should be cut and can be discarded.  
 +A few sheets have portions of the scrap/off-cut that could be saved. Those are noted by 'scrap' on Plate 4.  
 +No assembly required.

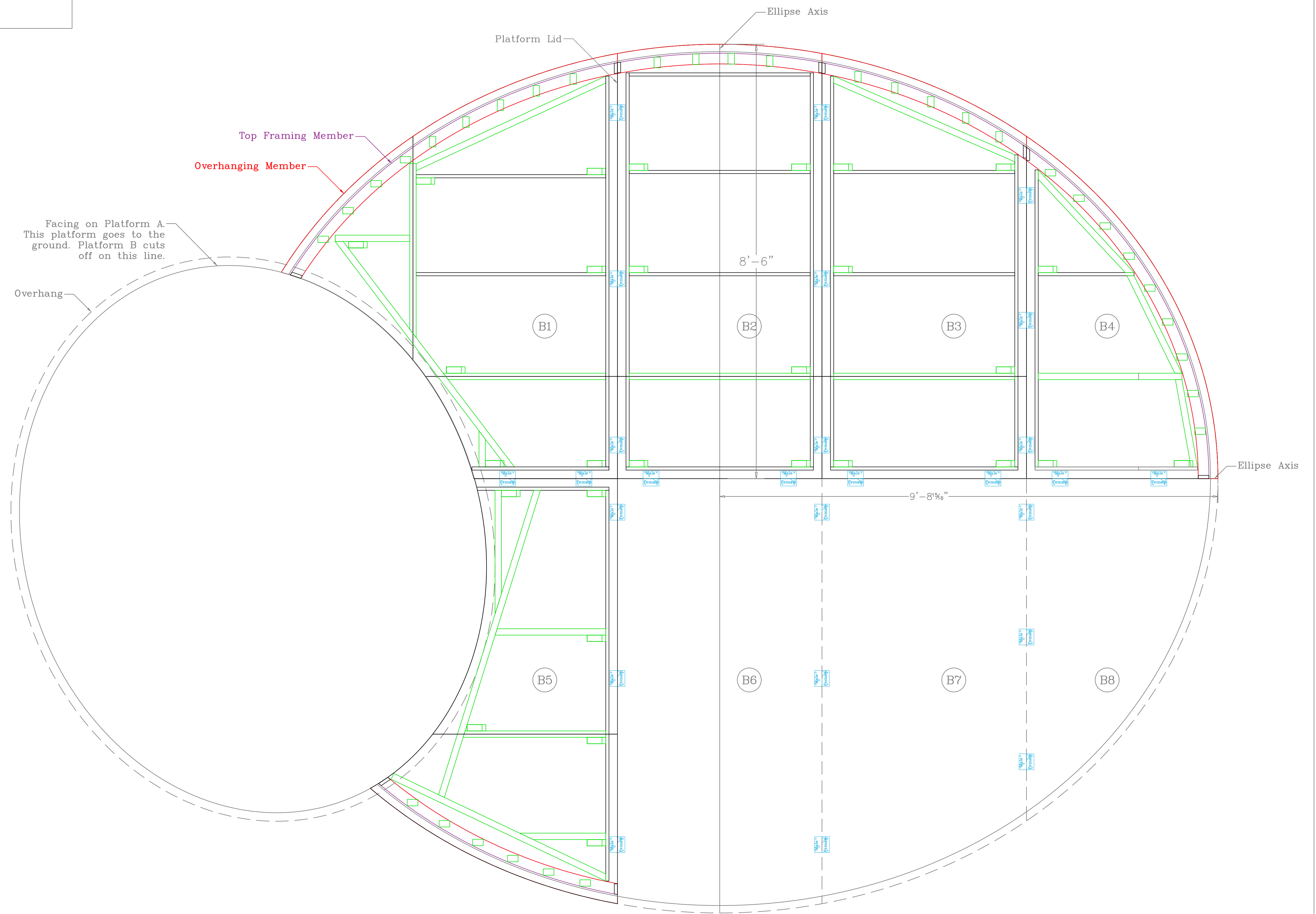
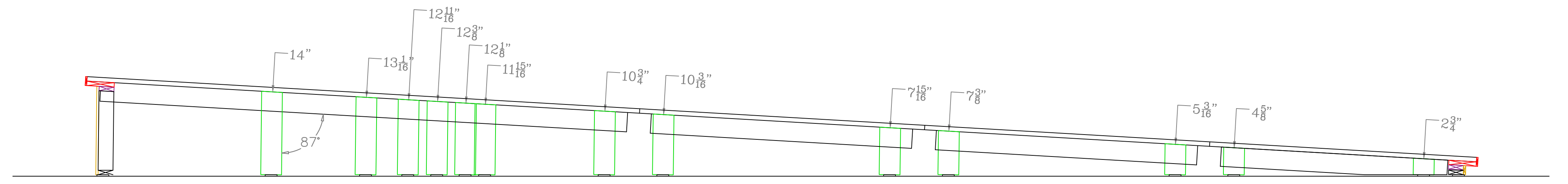

Notes:  
 +Plates 1, 2, 3 & 5 show how these plywood pieces will be used, but aren't critical to the cutting of them.  
 +Plate 4 & 5 show all the sheets that need to be CNC cut. 'X's here indicate which side of the lines should be cut and can be discarded.  
 +A few sheets have portions of the scrap/off-cut that could be saved. Those are noted by 'scrap' on Plate 4.  
 +No assembly required.

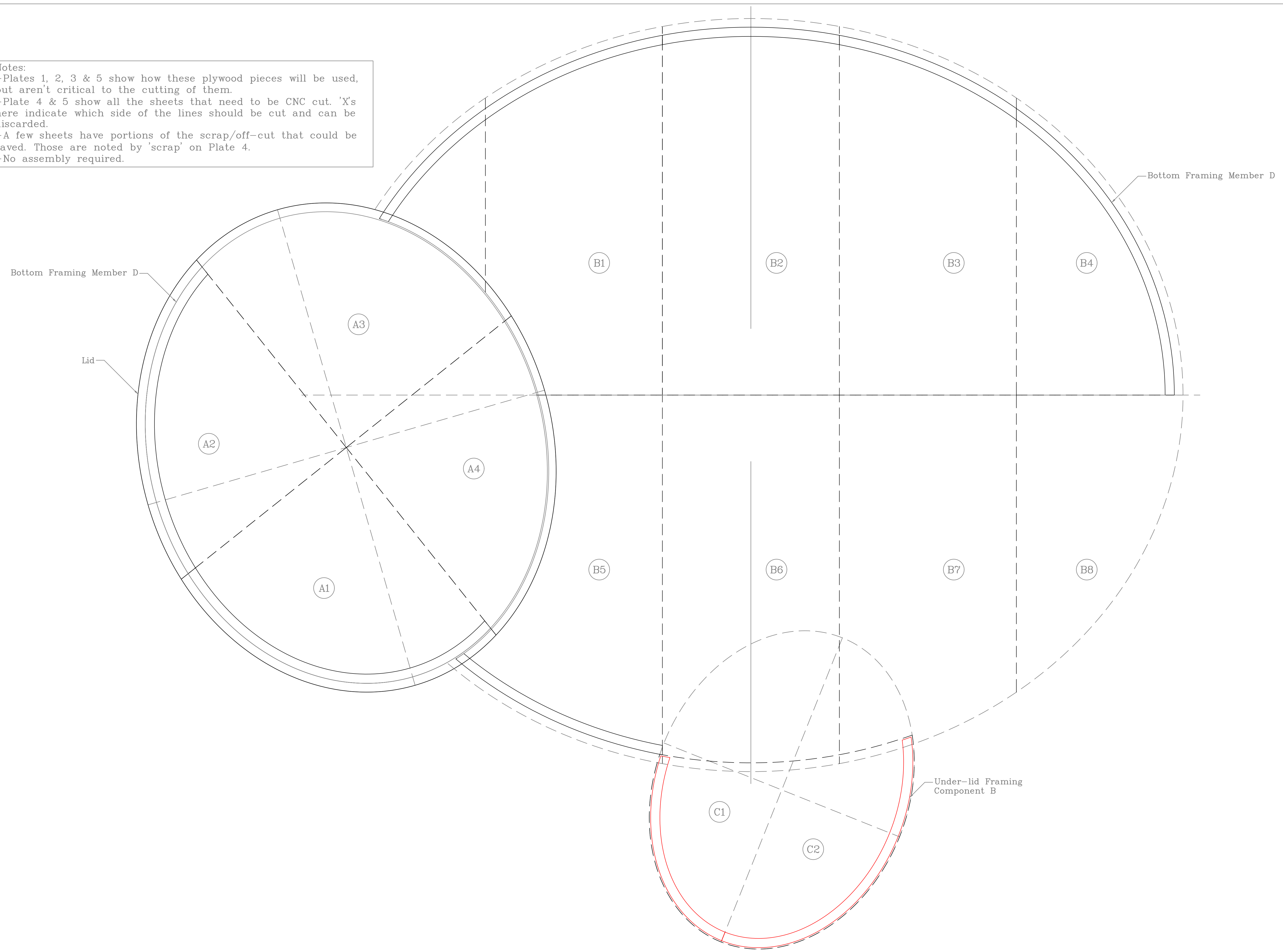

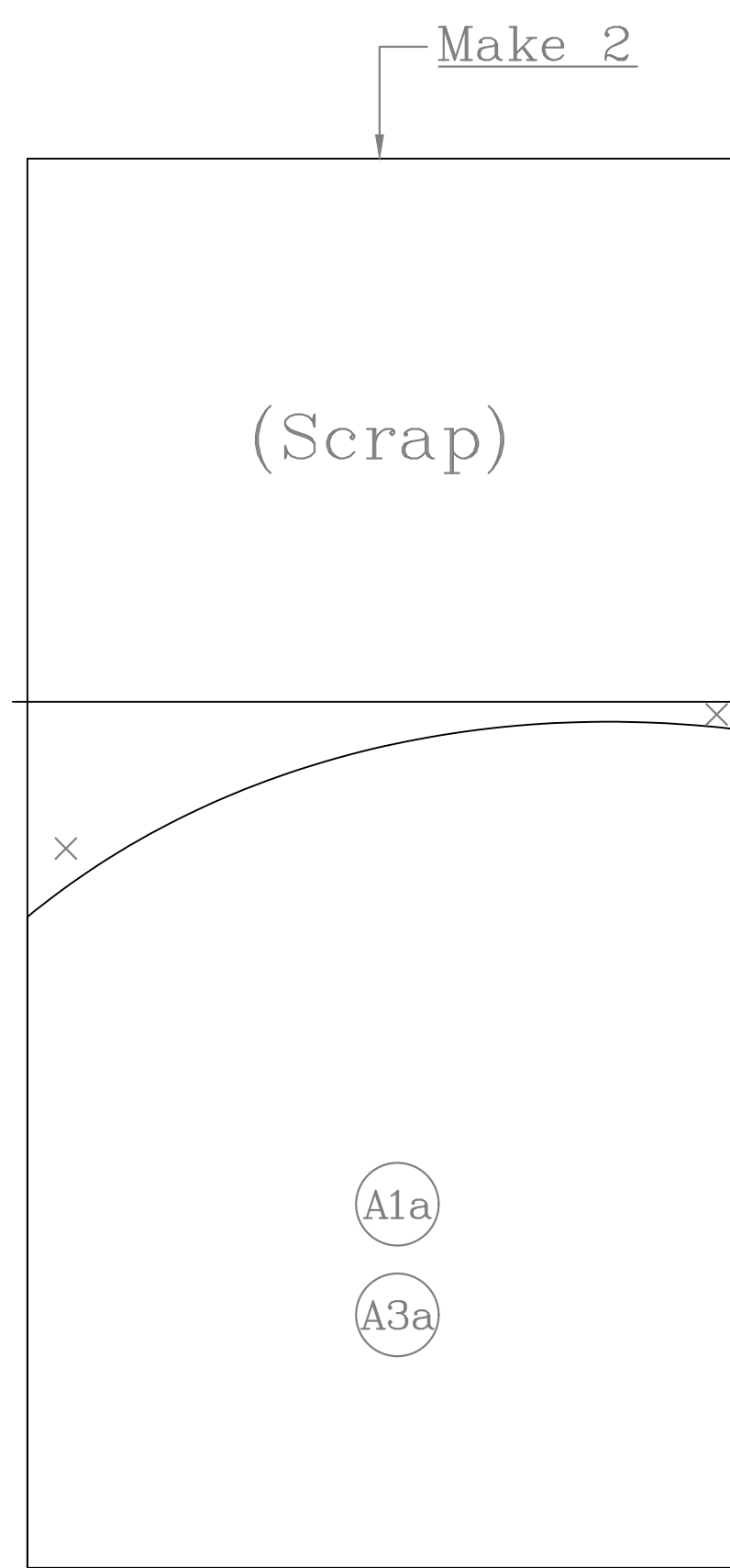

Sheet 1

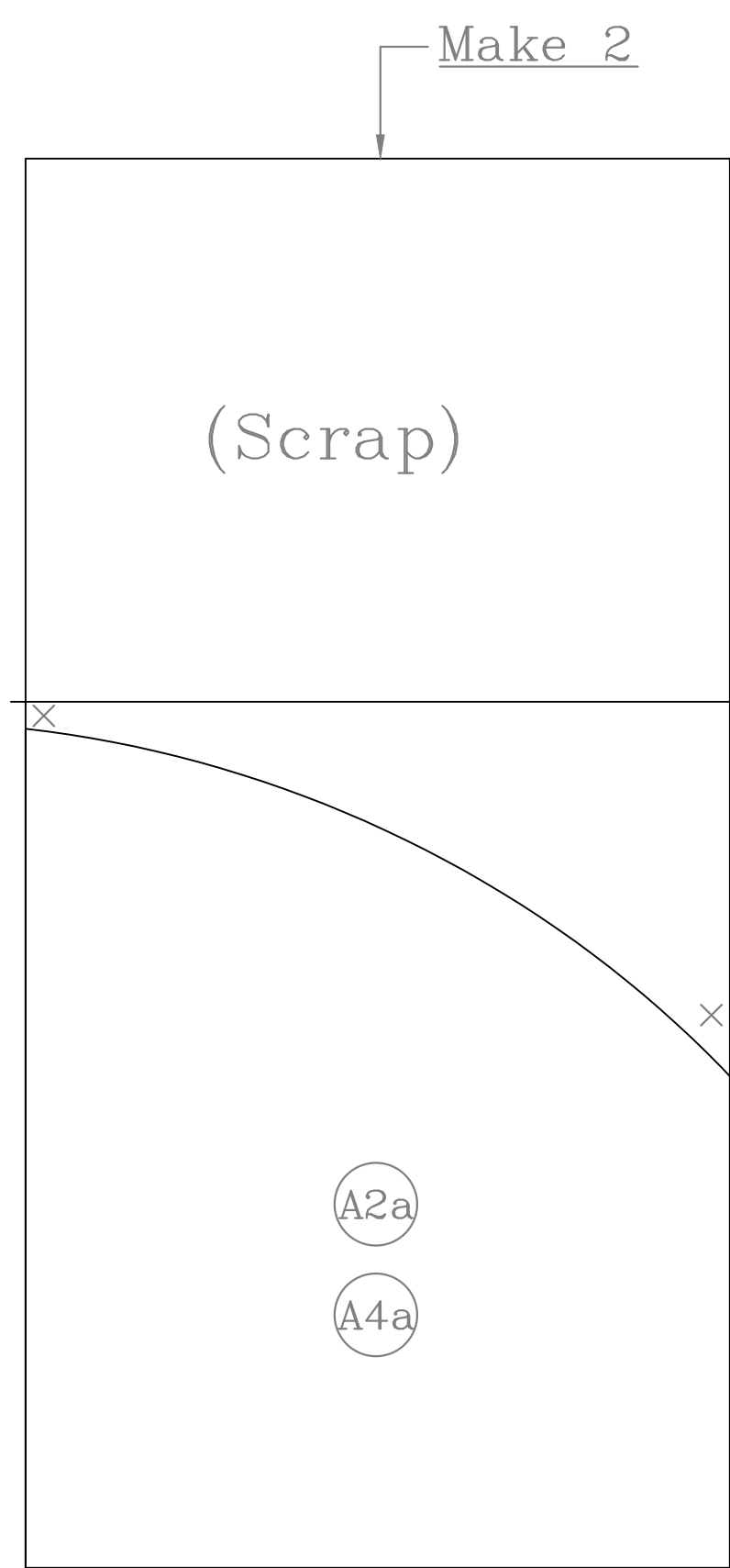

Sheet 2

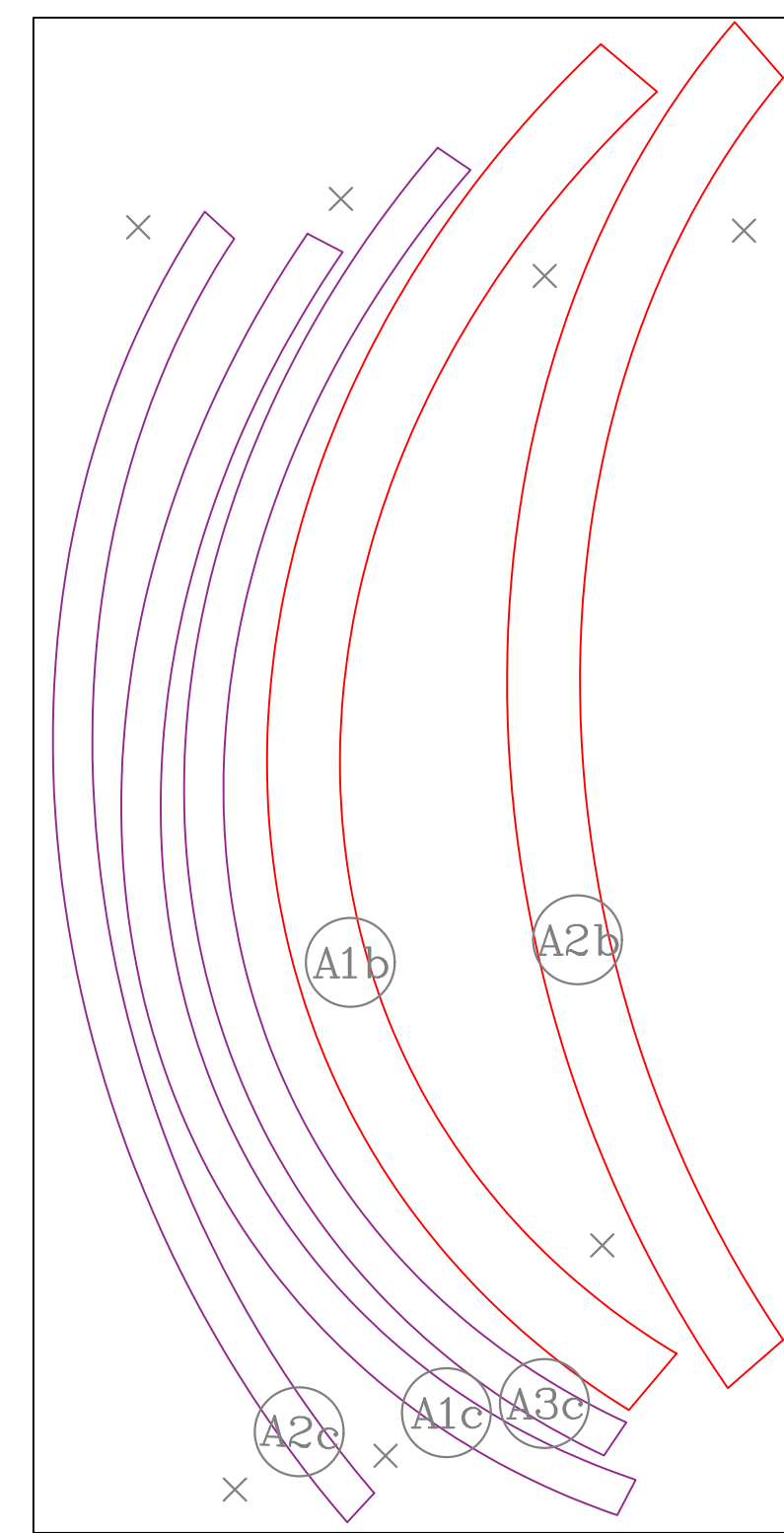

Sheet 3

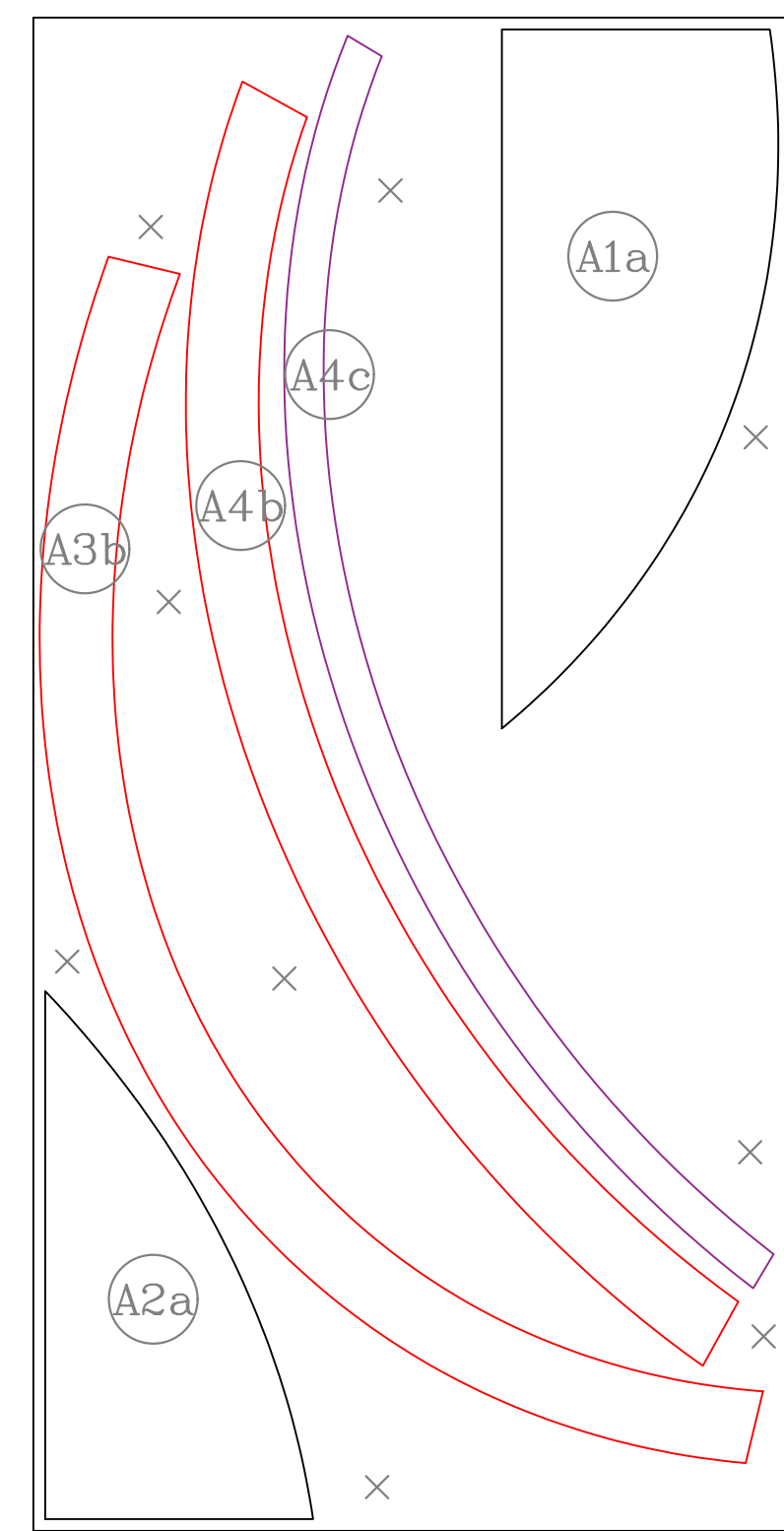

Sheet 4

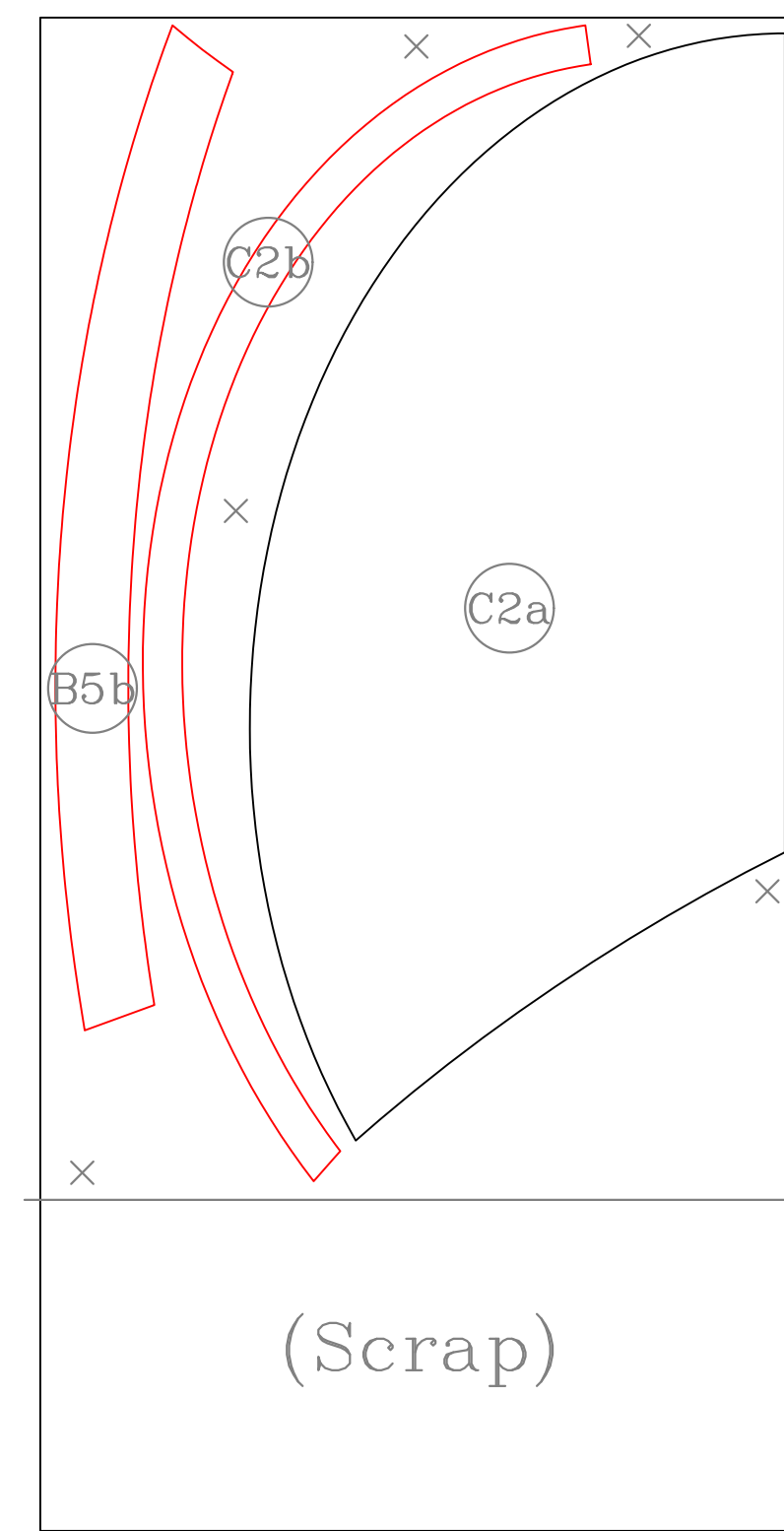

Sheet 5

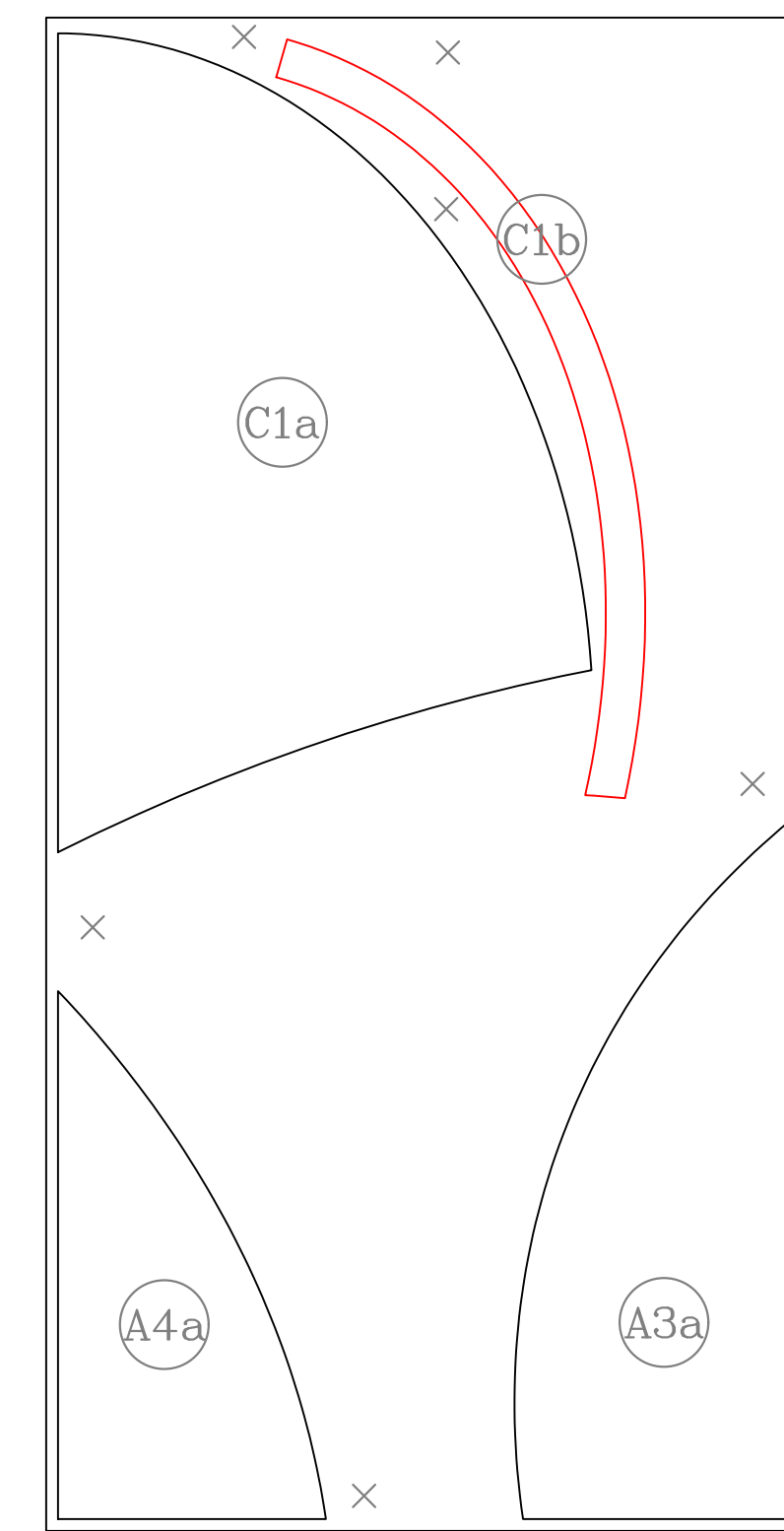

Sheet 6

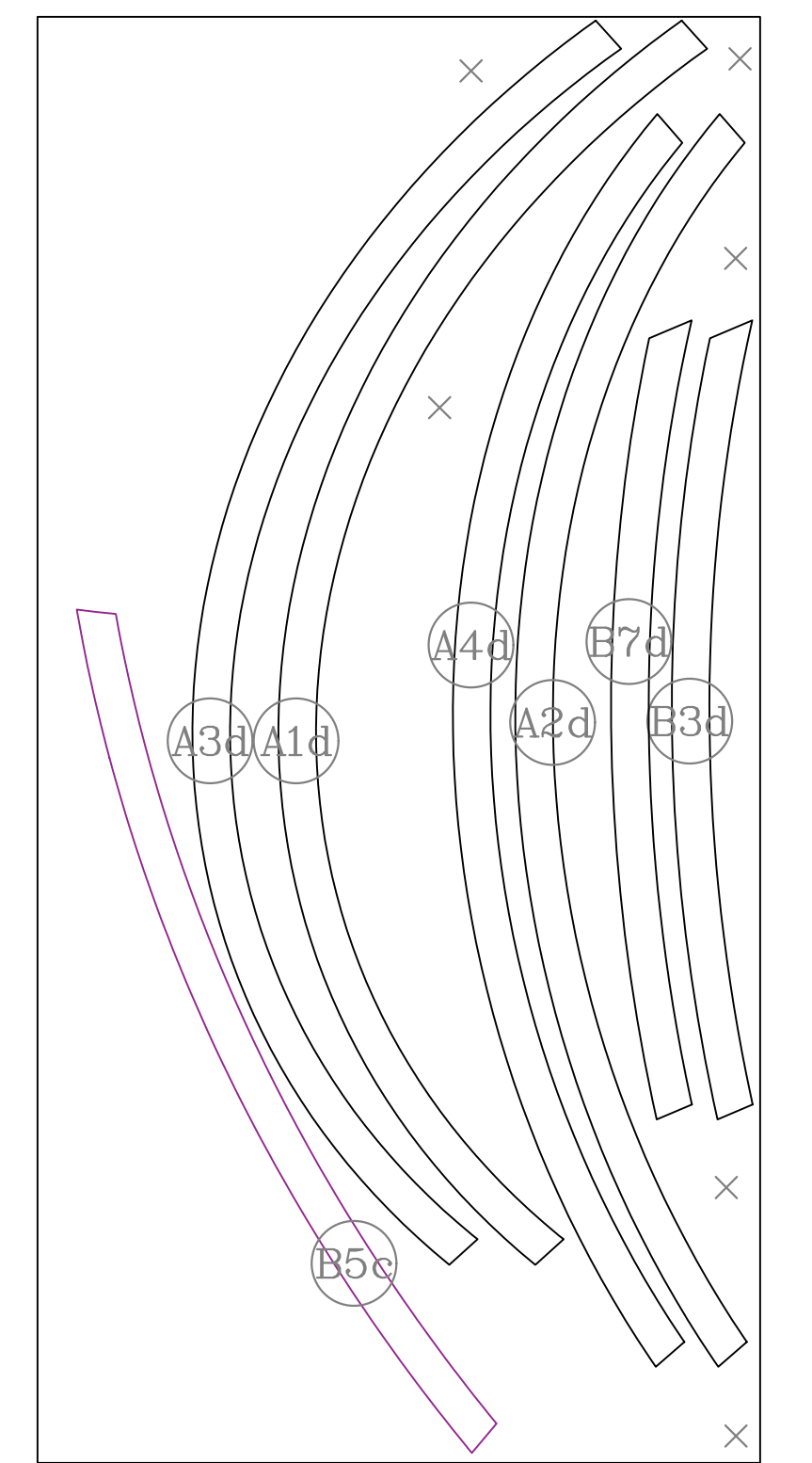

Sheet 7

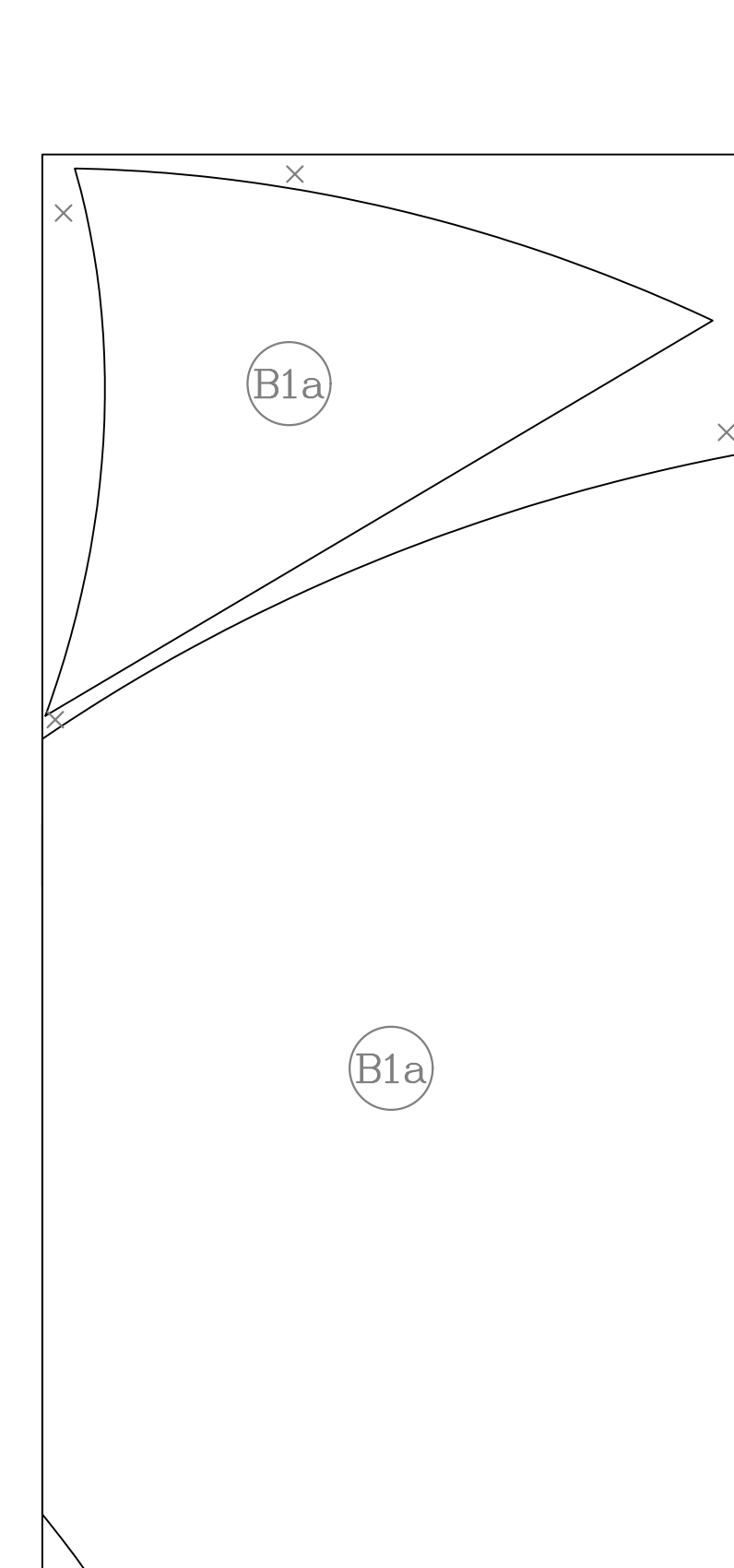

Sheet 8

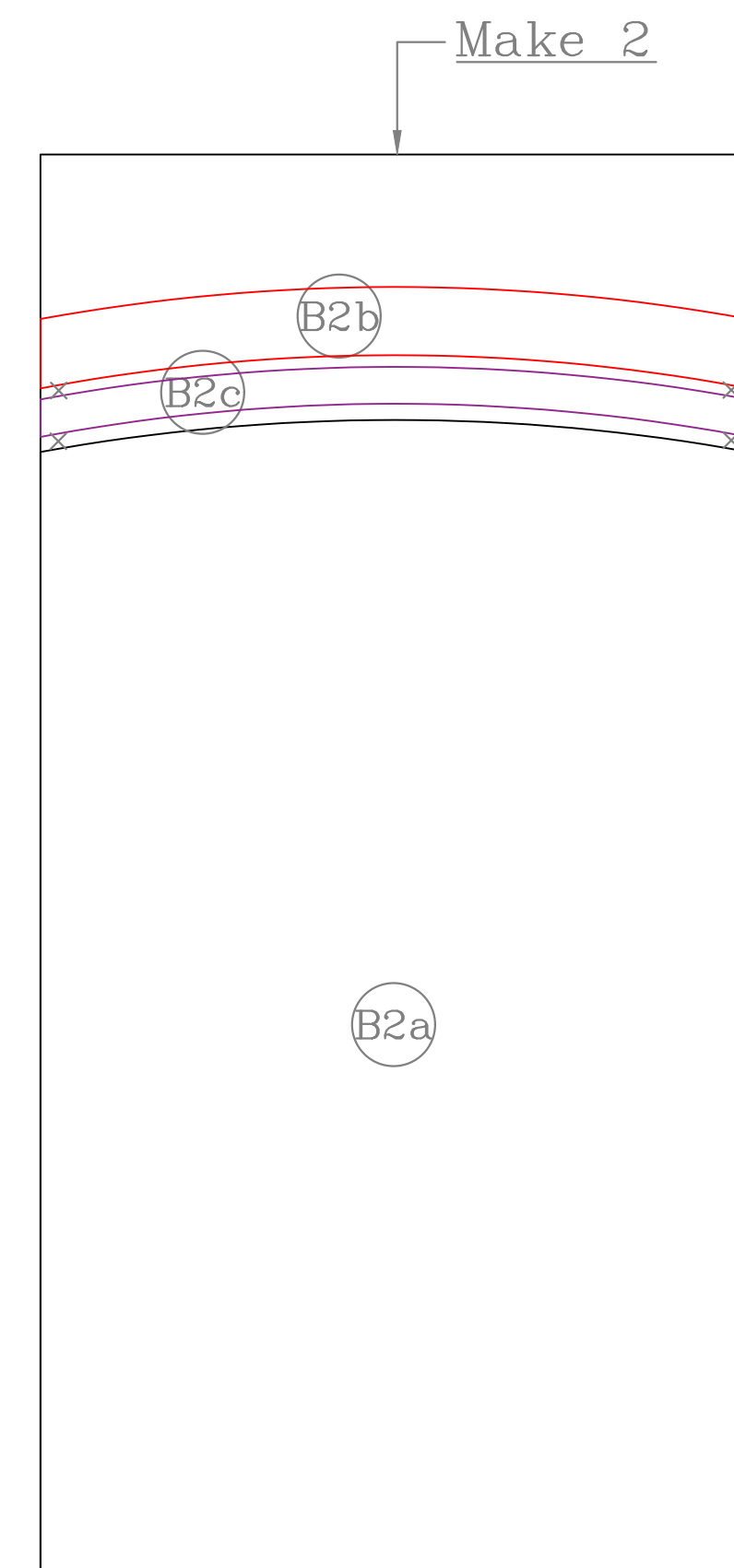

Sheet 9

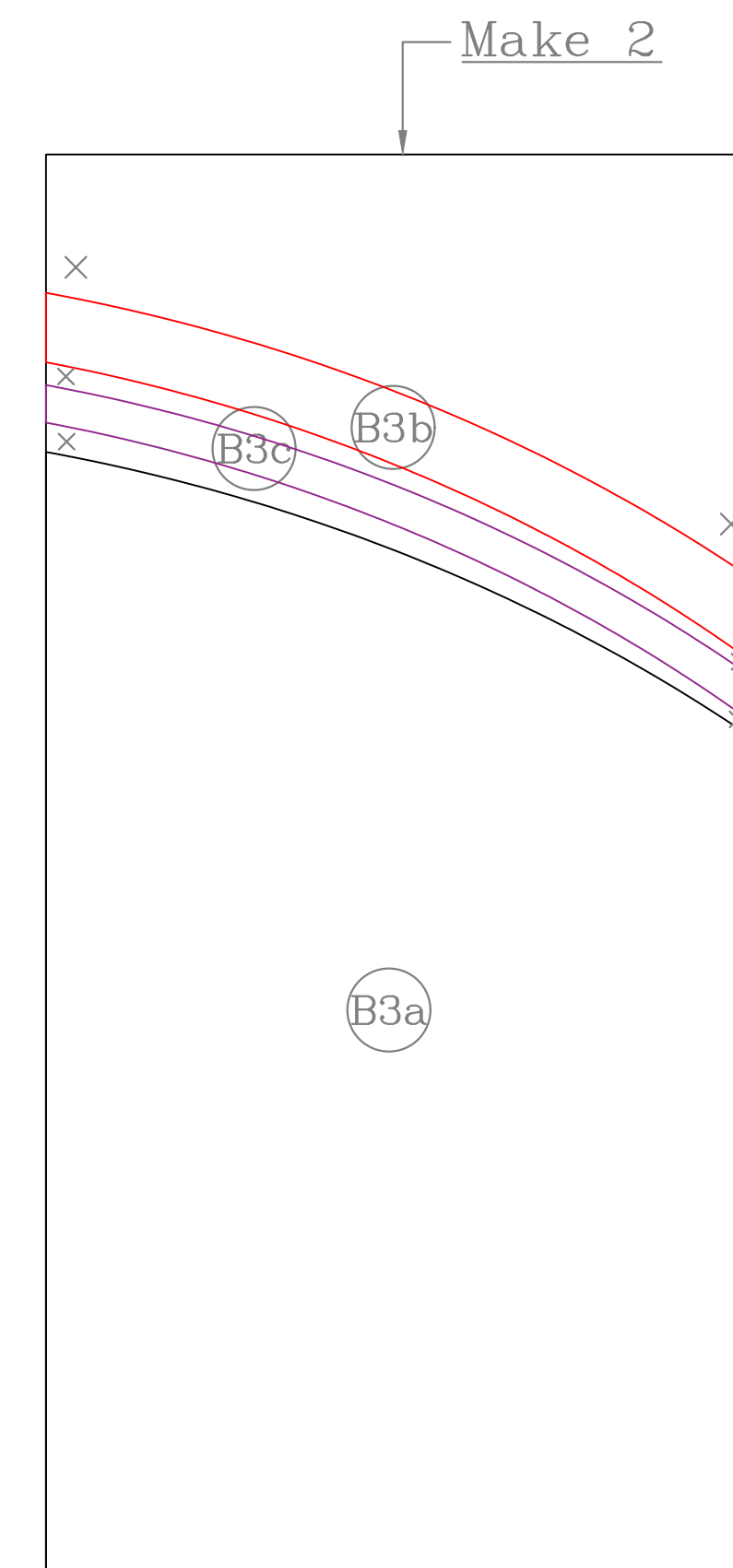

Sheet 10

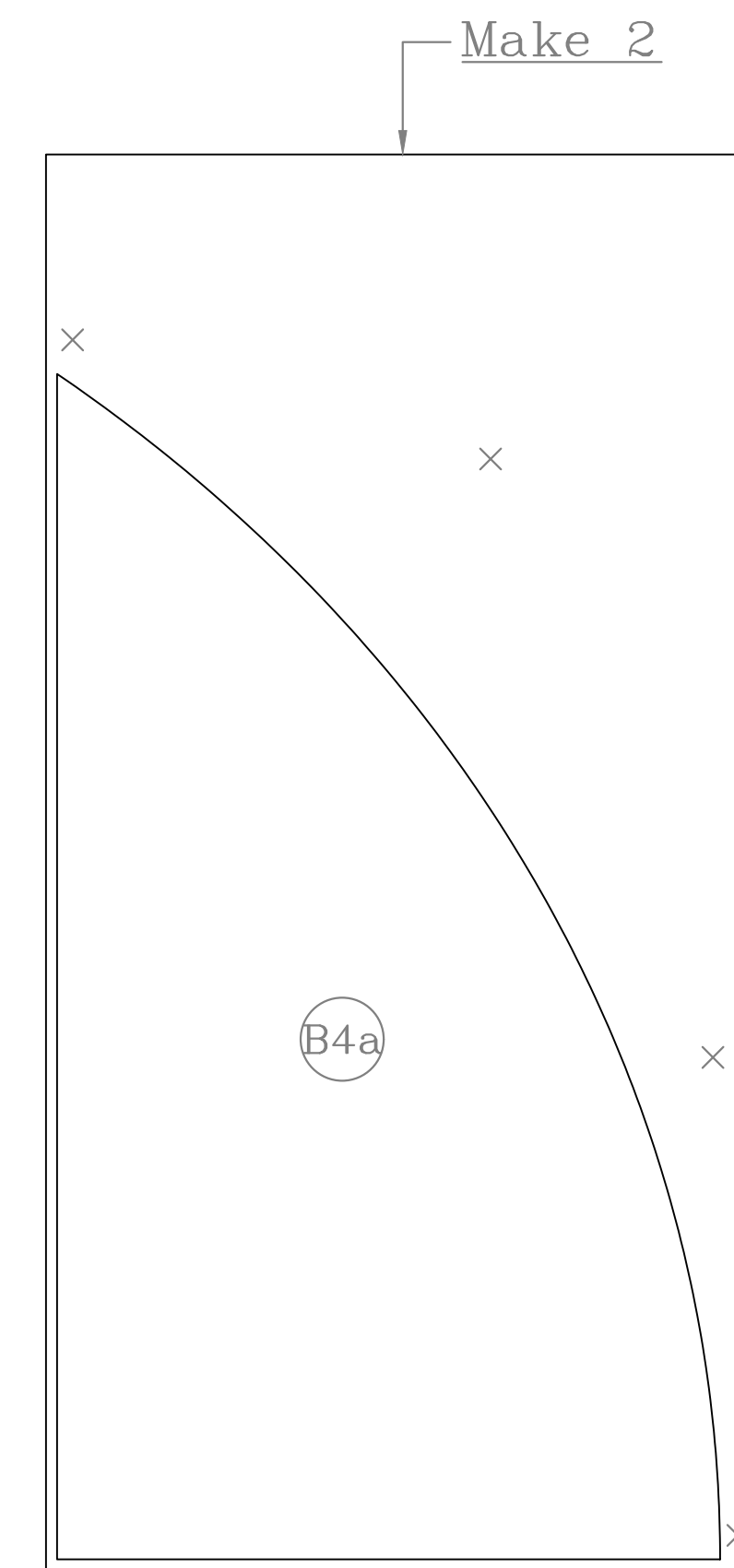

Sheet 11

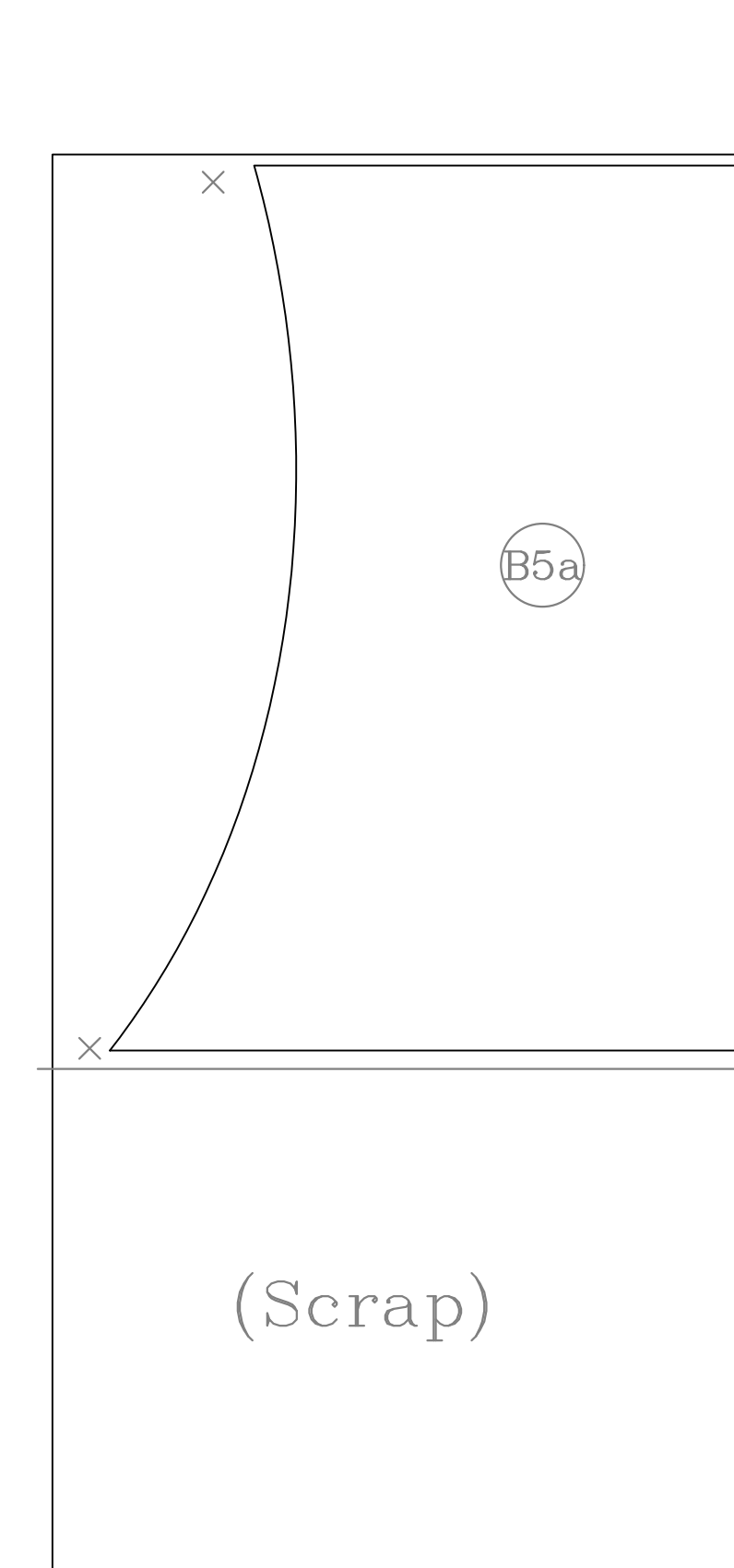

Sheet 12

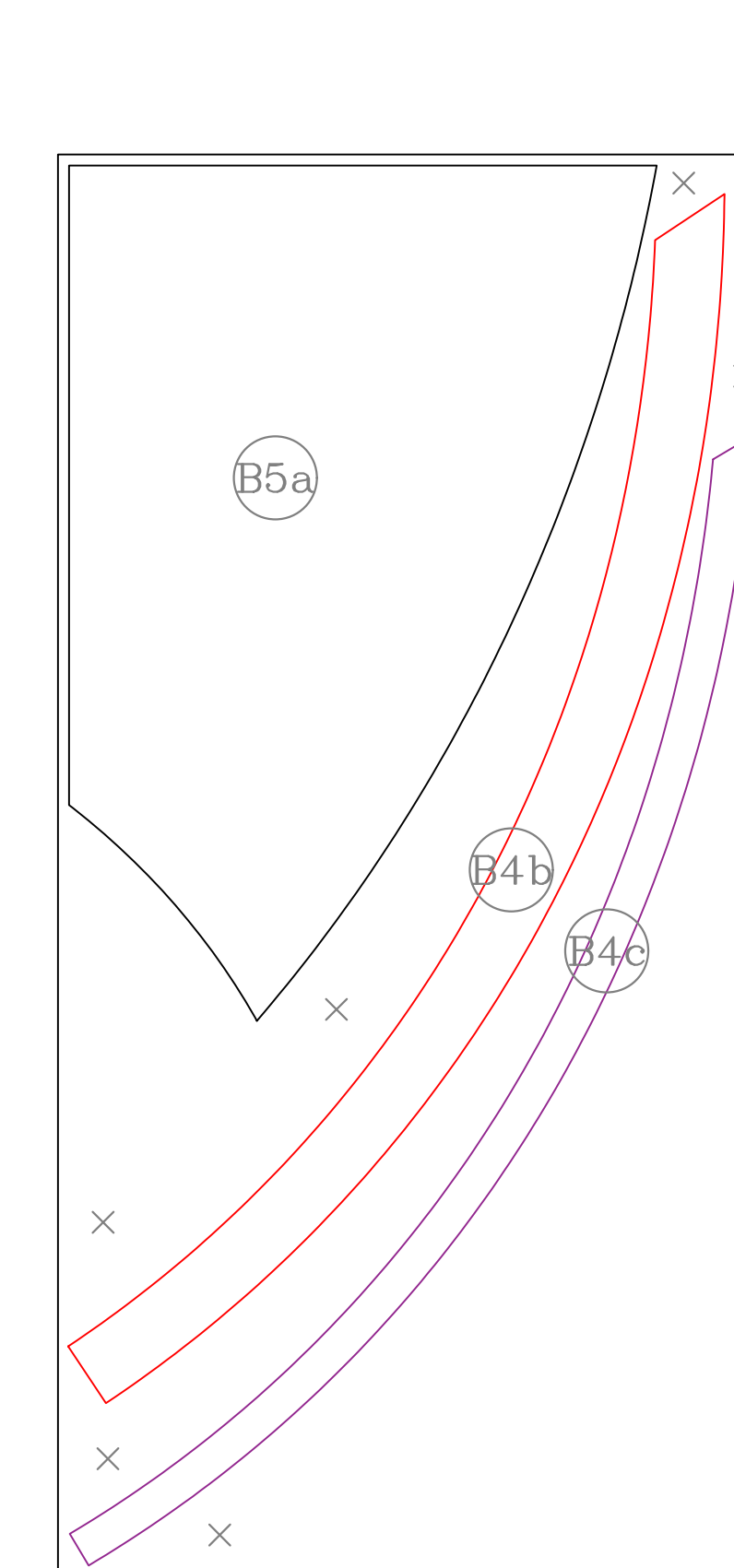

Sheet 13

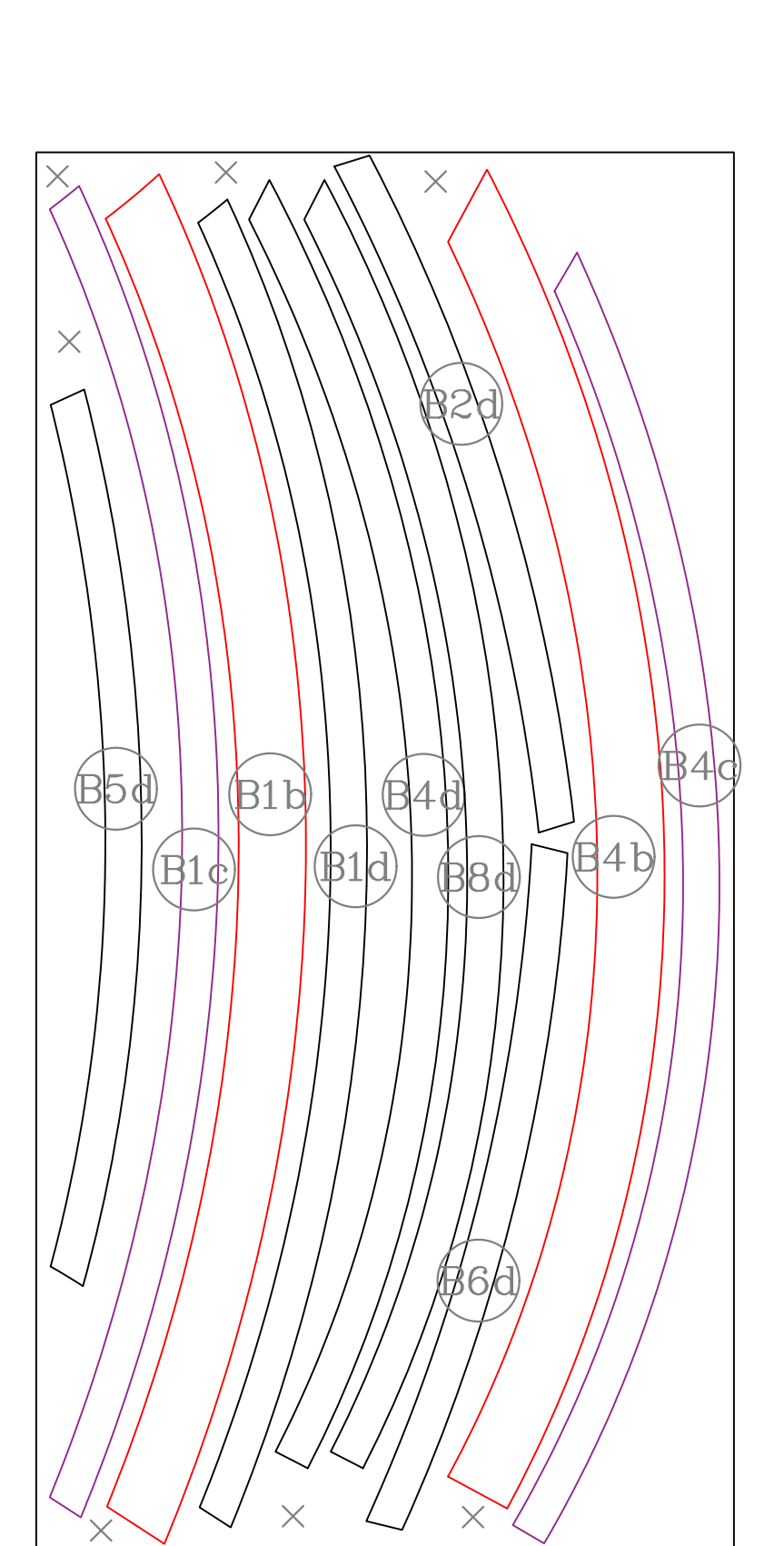

Sheet 14

Notes: All Ellipse pieces are cut from  $\frac{3}{4}$ " plywood. Please label pieces in pencil.

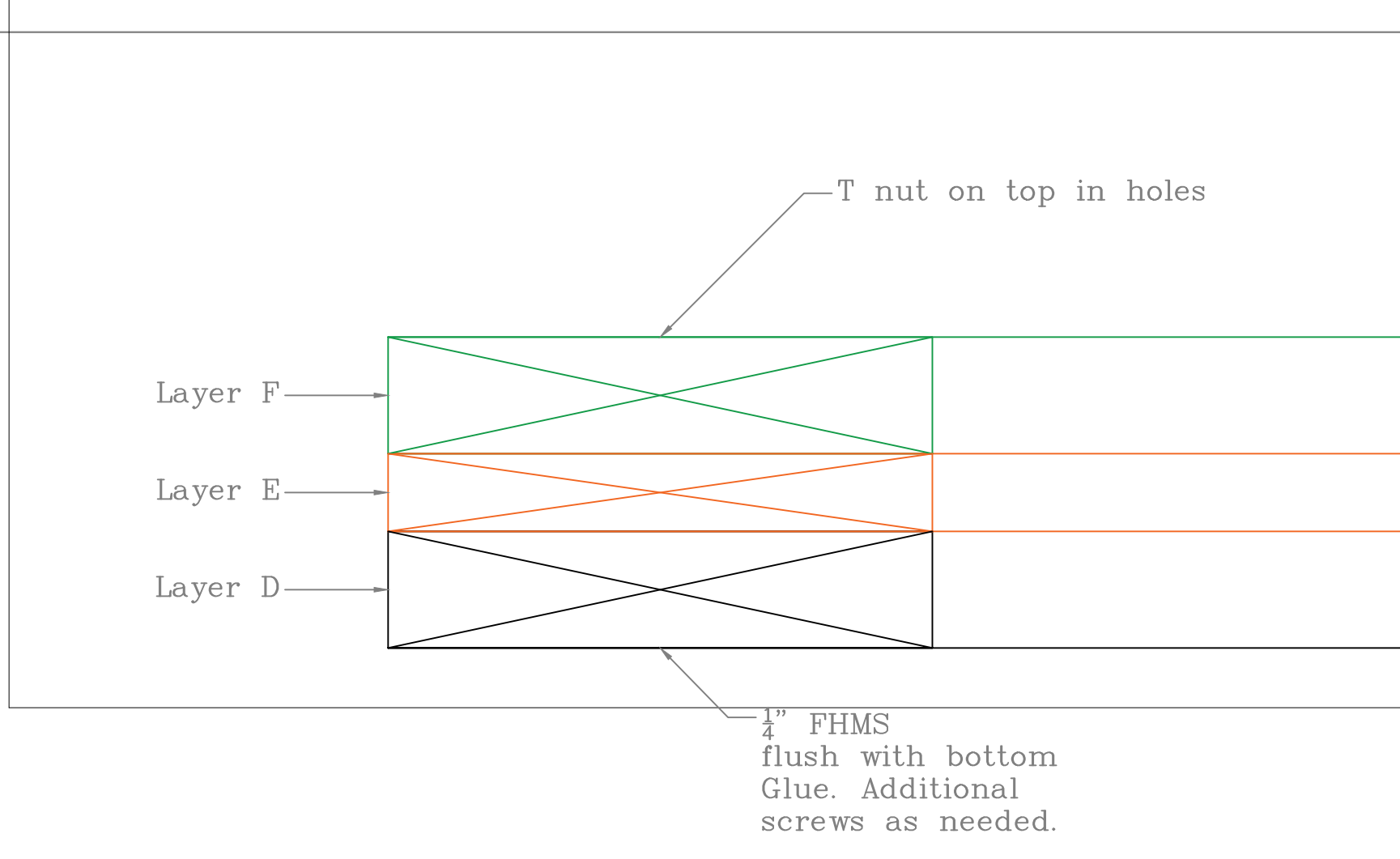

Composition  
Scale = 1:1

Holes drilled in all ellipse pieces. Not shown here for clarity.

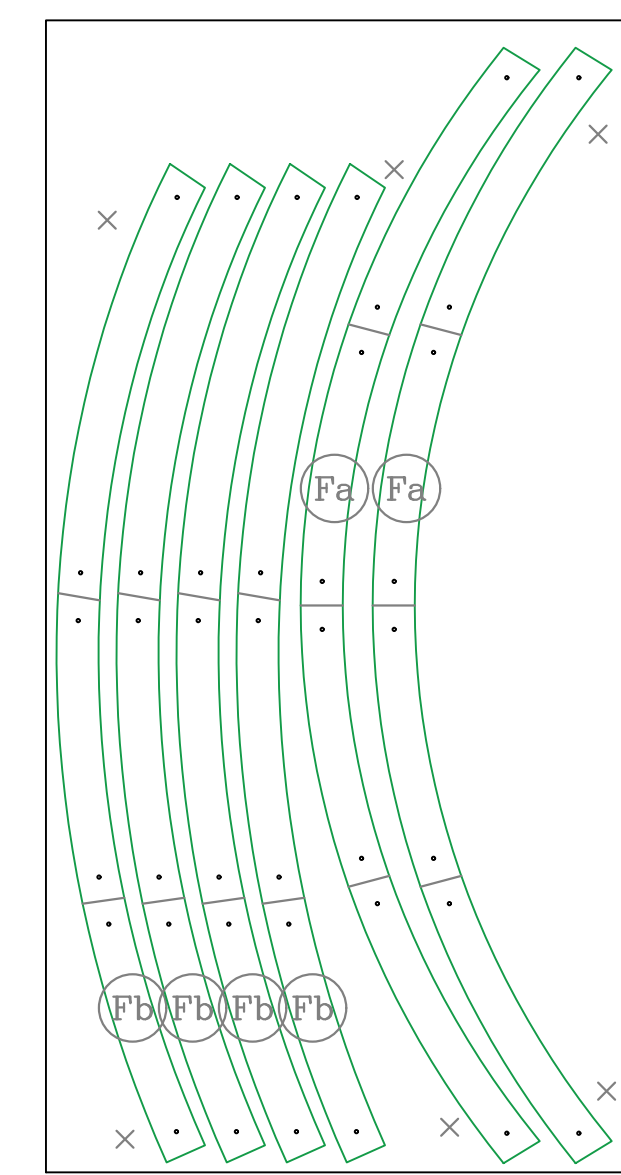
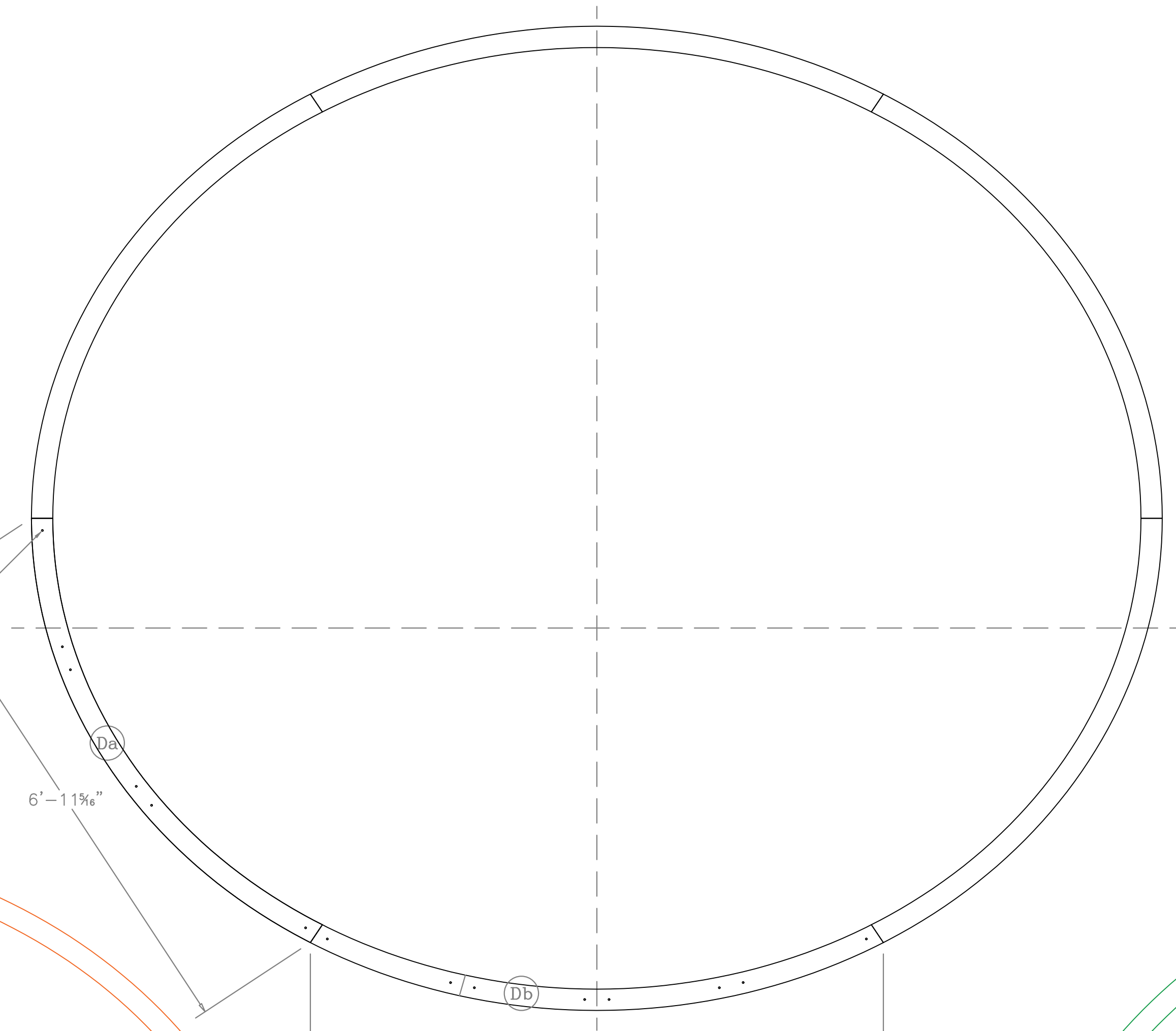

Sheet 15

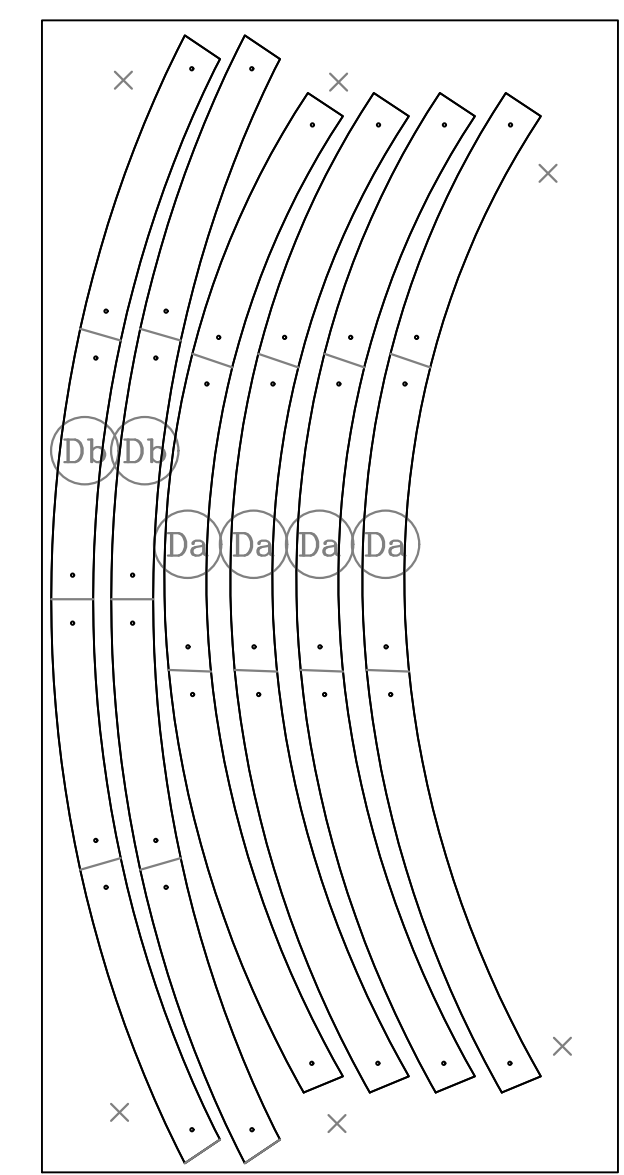

Sheet 16

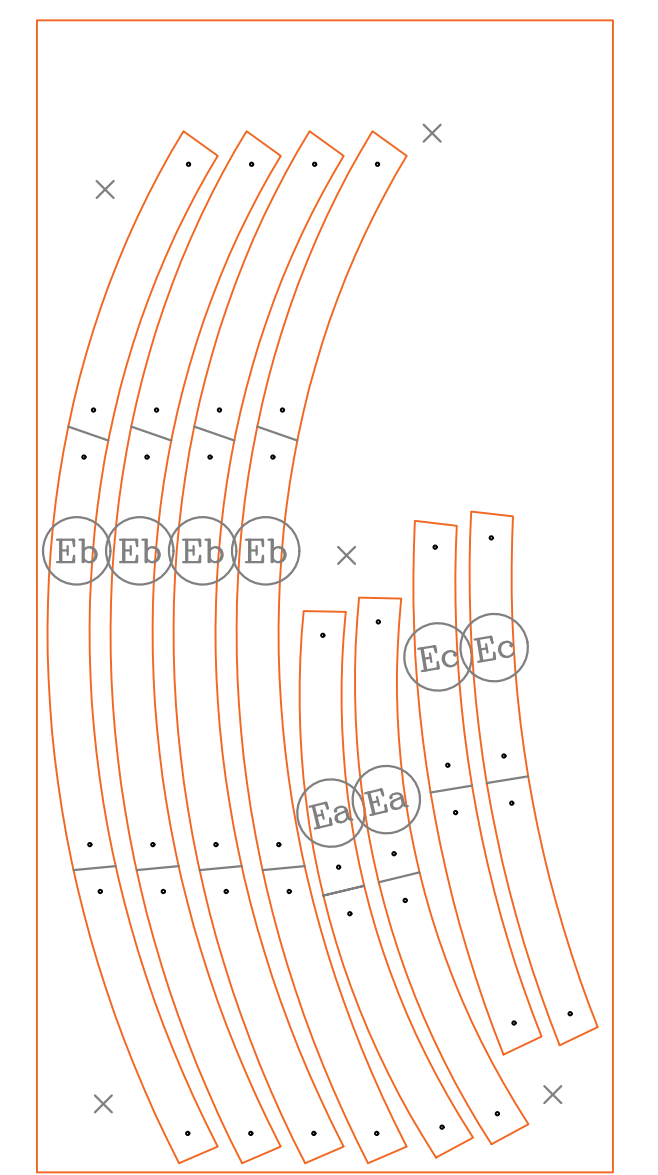

Sheet 17  
(1/2" Plywood)

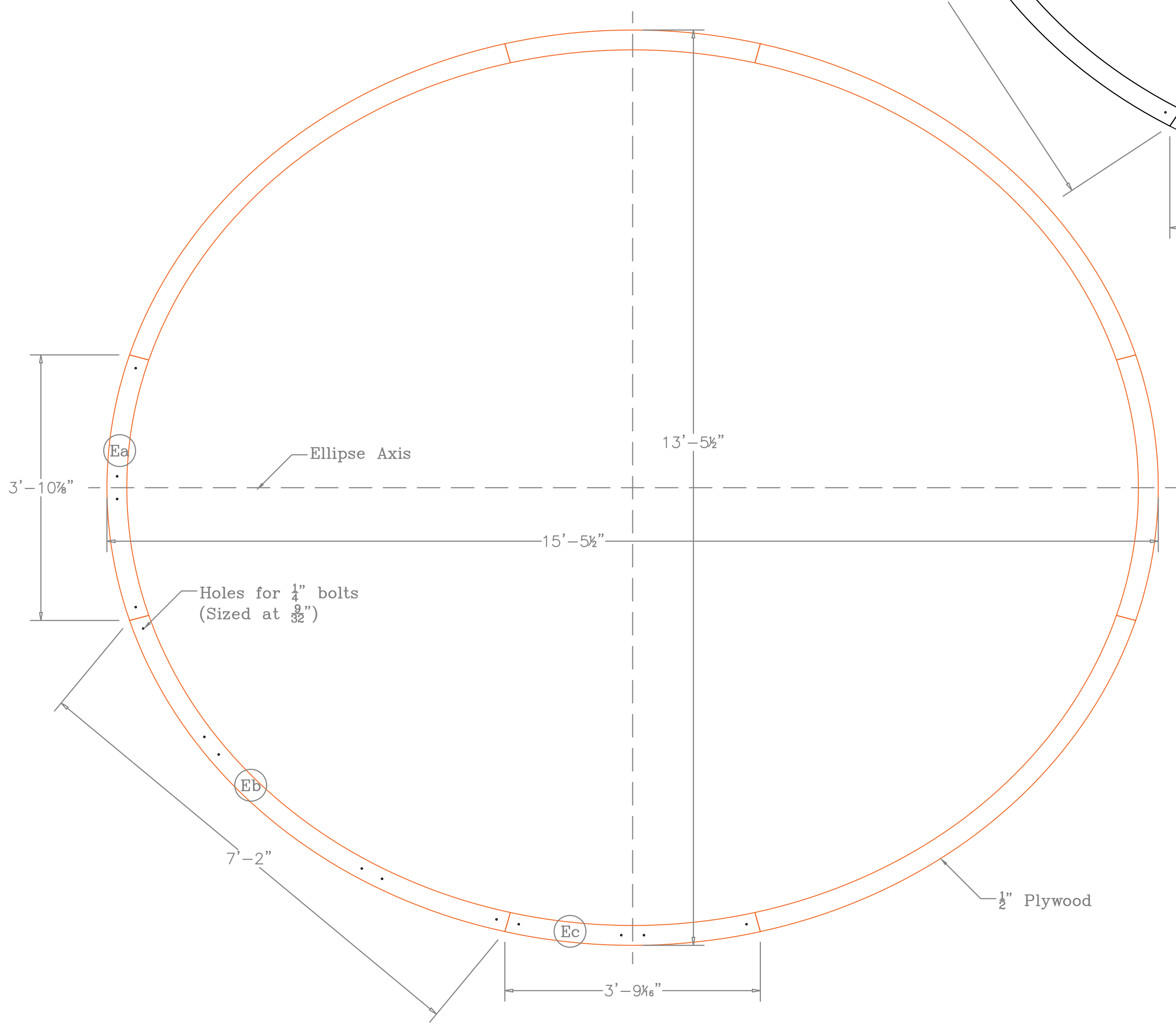

Layer 2 (E)  
1/2" Plywood

Layer 1 (D)  
3/4" Plywood

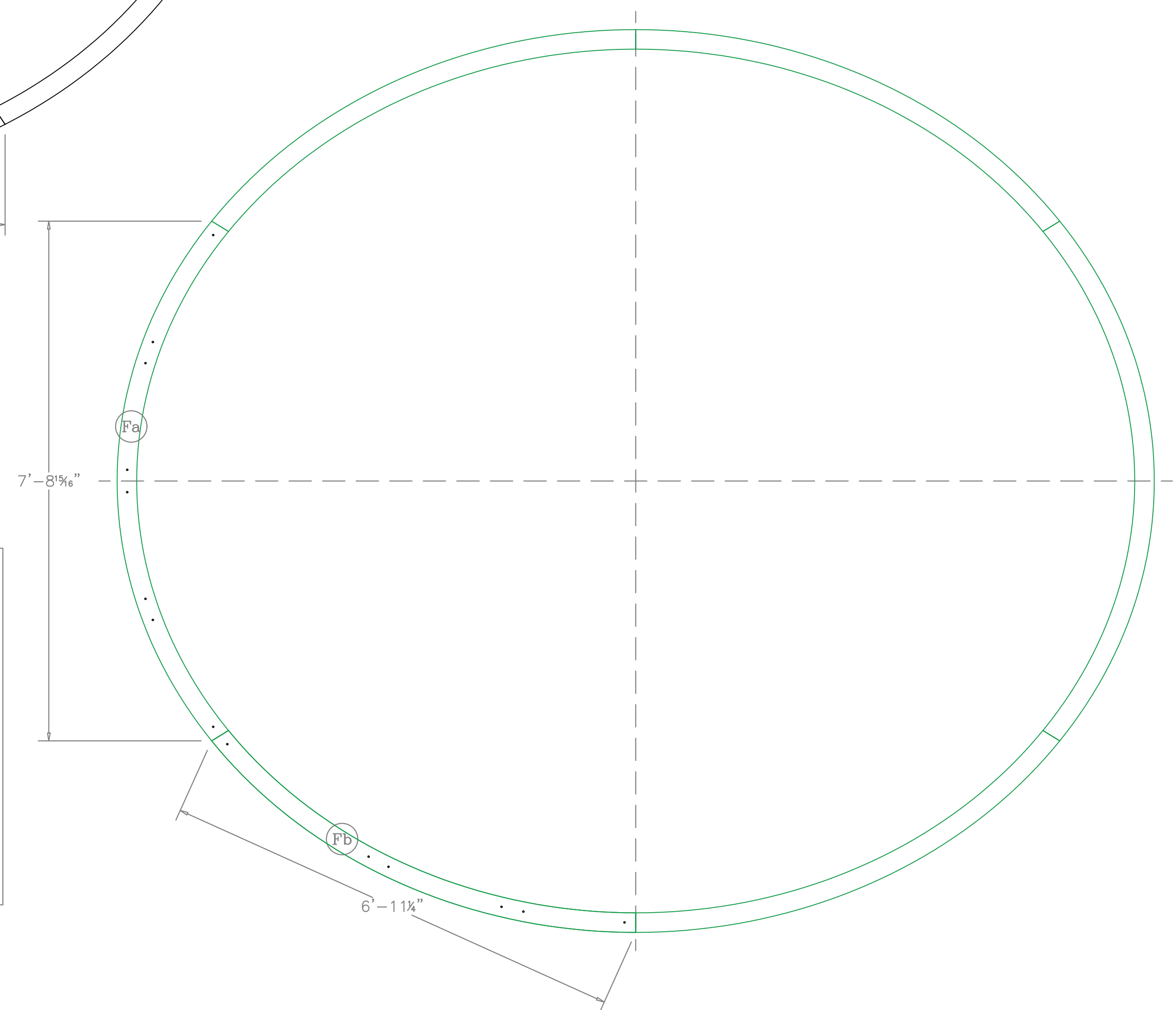

Layer 3 (F)  
3/4" Plywood

Notes:  
 +This ellipse will hang overhead, but is too large to be preassembled before moving into the theater. It will be glued, screwed and bolted in two halves then fully assembled once moved into the theater.  
 +Bolt holes are marked and are sized at 3/32" for 1/4" flat head machine screws. Adjust hole size to nearest as discussed.  
 +Bolt holes for eye bolts will be drilled in space.  
 +No assembly required.

5	Overhead Ellipse	American Players Theatre 2023	Scale: 3/4" = 1'-0"	Director: Laura Rook	TD: Bill Duwell.
	Production: Once Upon a Bridge		Date: 4/28/2023	Scenic Design: Lawrence Moten	ATD: Doug Dion

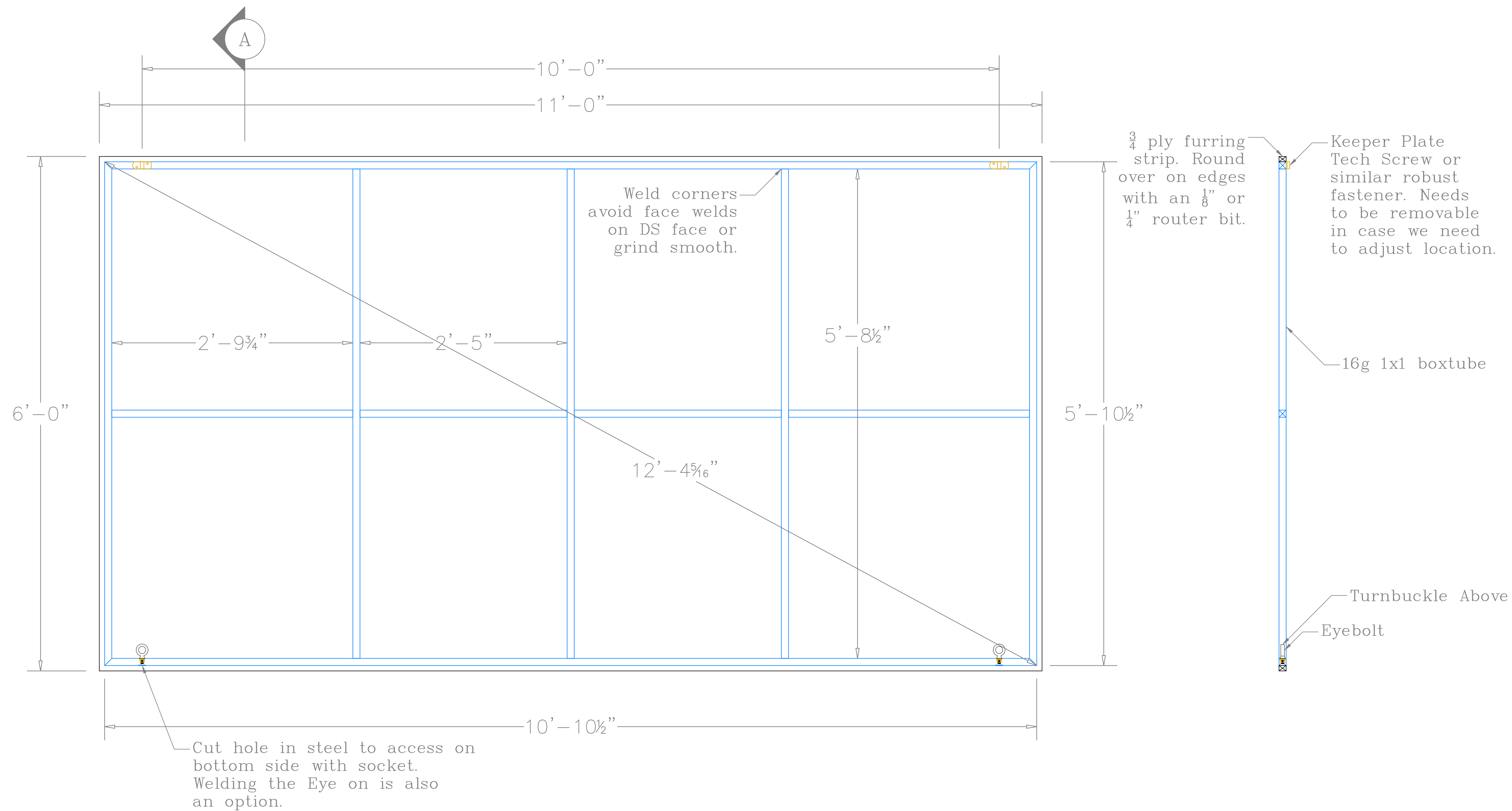

1 Projection Screen  
1-1/2" = 1'-0"

2 Section  
1-1/2" = 1'-0"

Notes:  
 +All Geometry shown here is the ellipse as seen from the top.  
 +Raked ellipses may have slightly different dimensioning when measuring along their aligned rake.

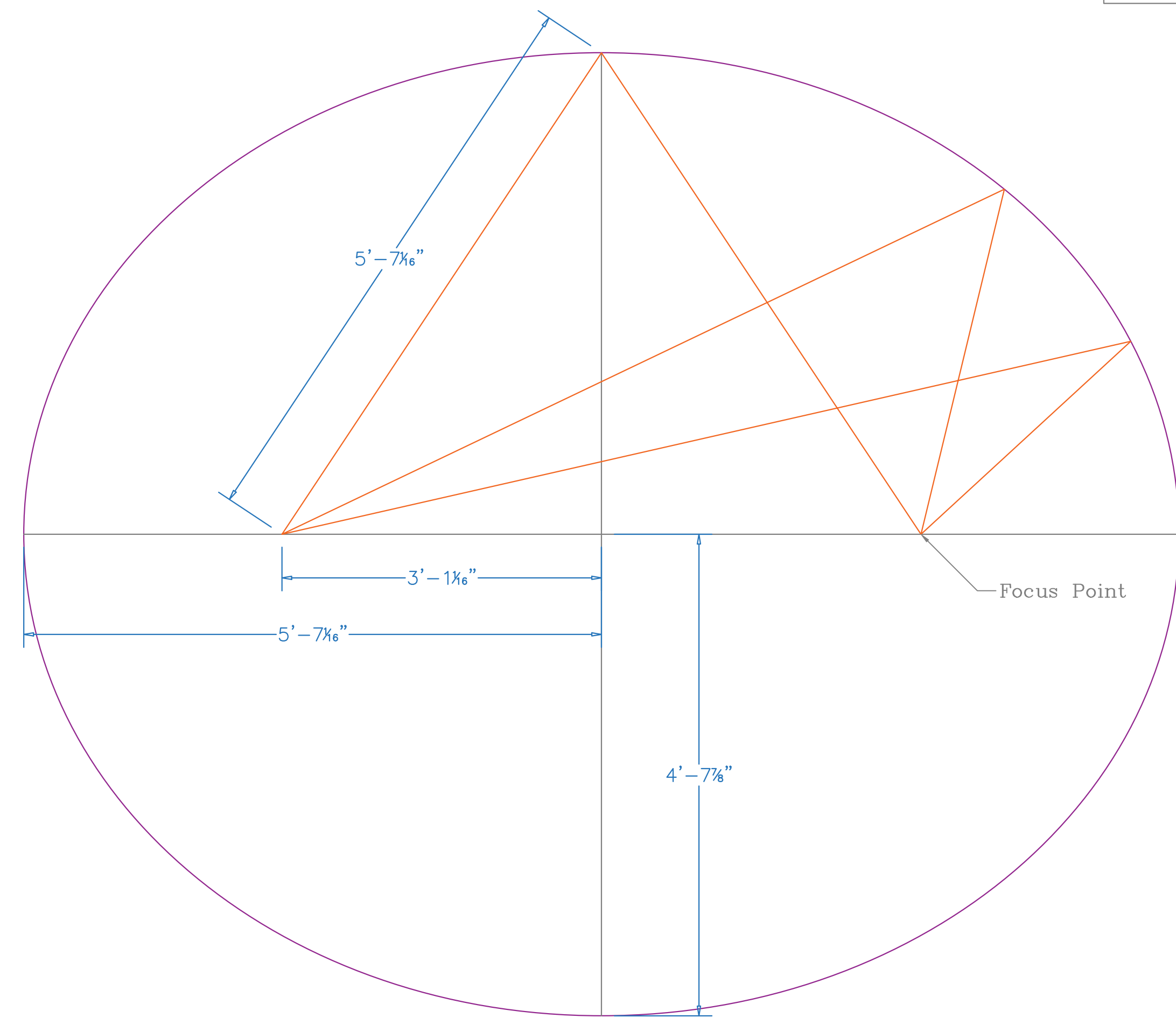

1 Ellipse A Geometry  
 1" = 1'-0"

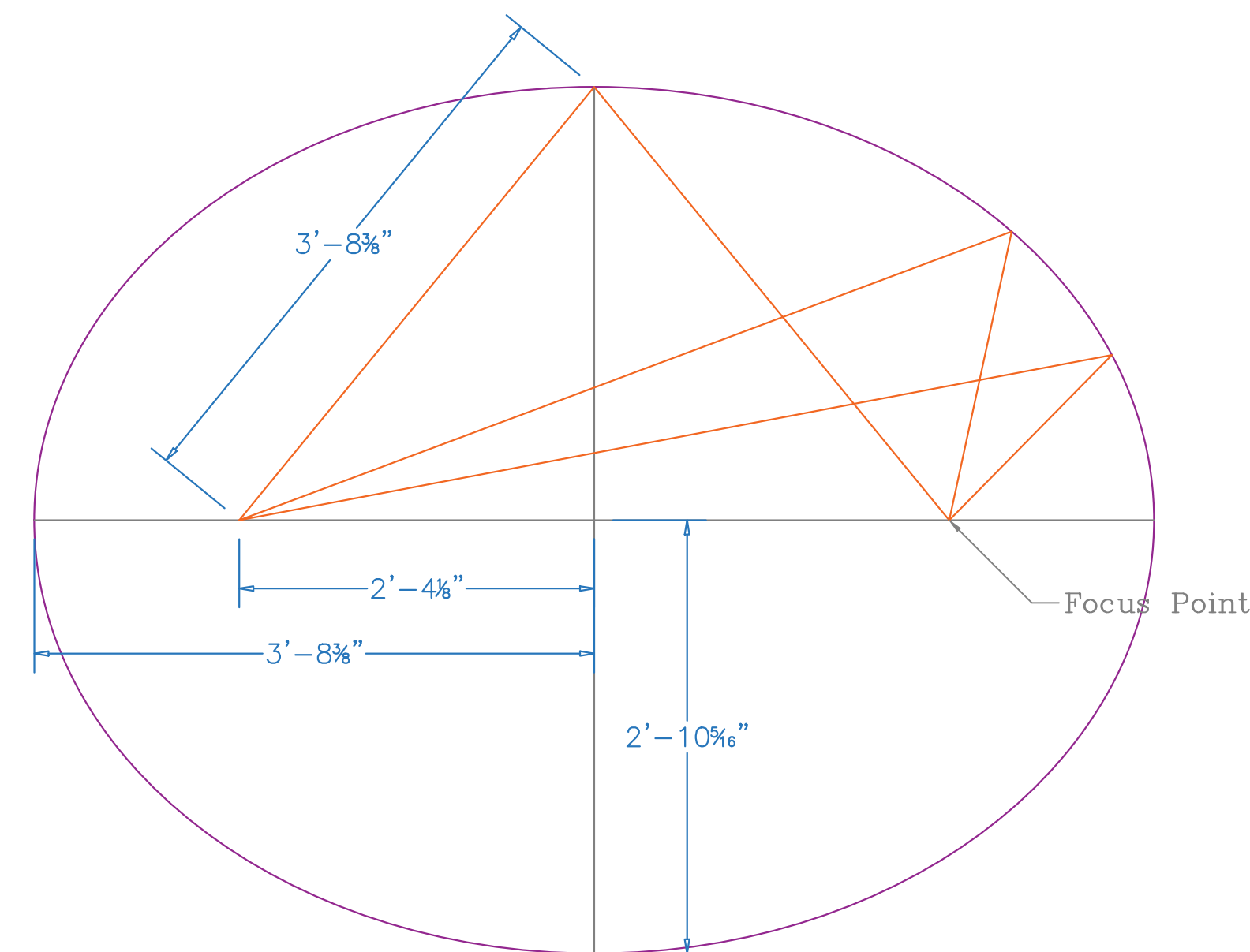

2 Ellipse C Geometry  
 1" = 1'-0"

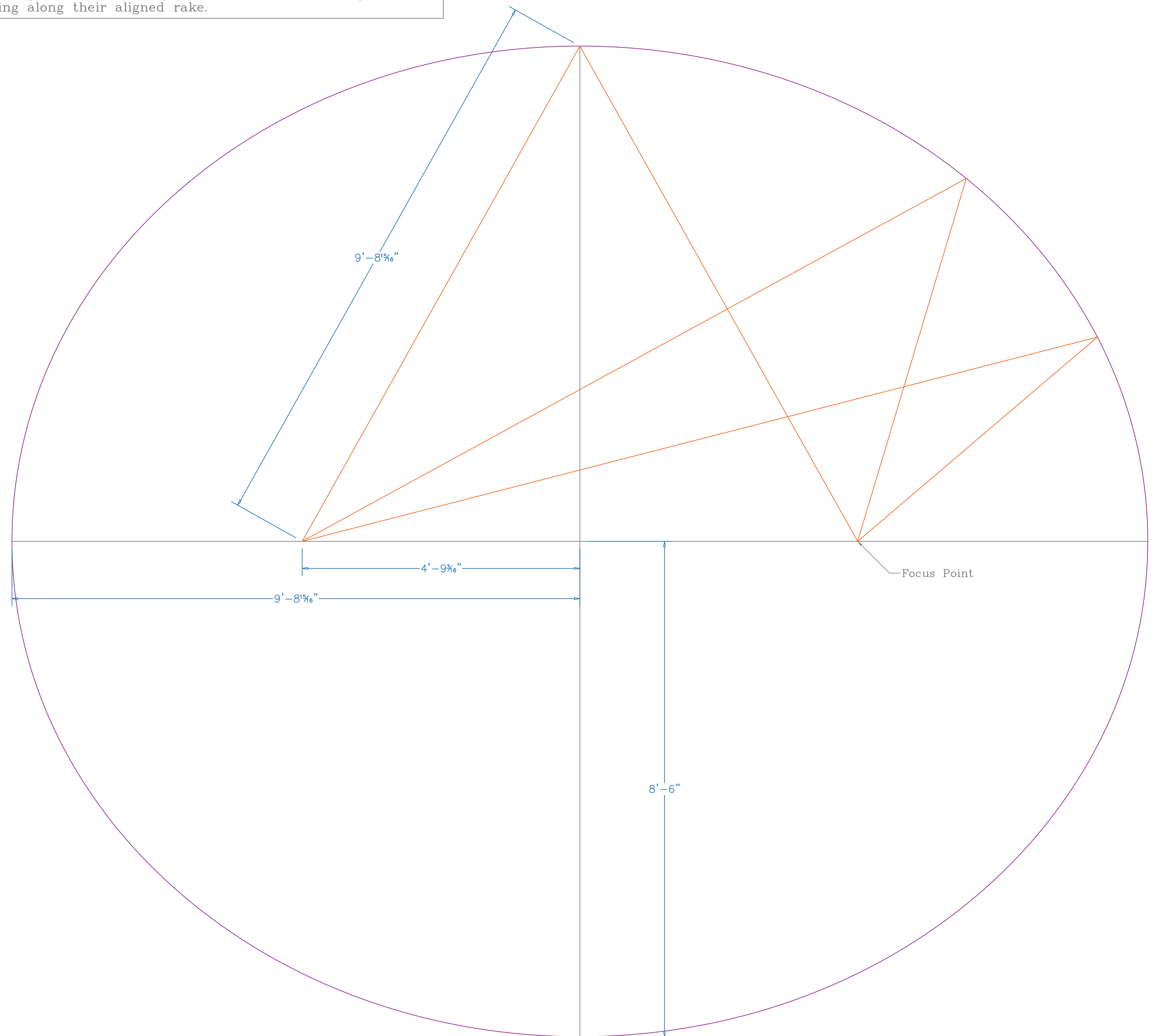

3 Ellipse B Geometry  
 1" = 1'-0"



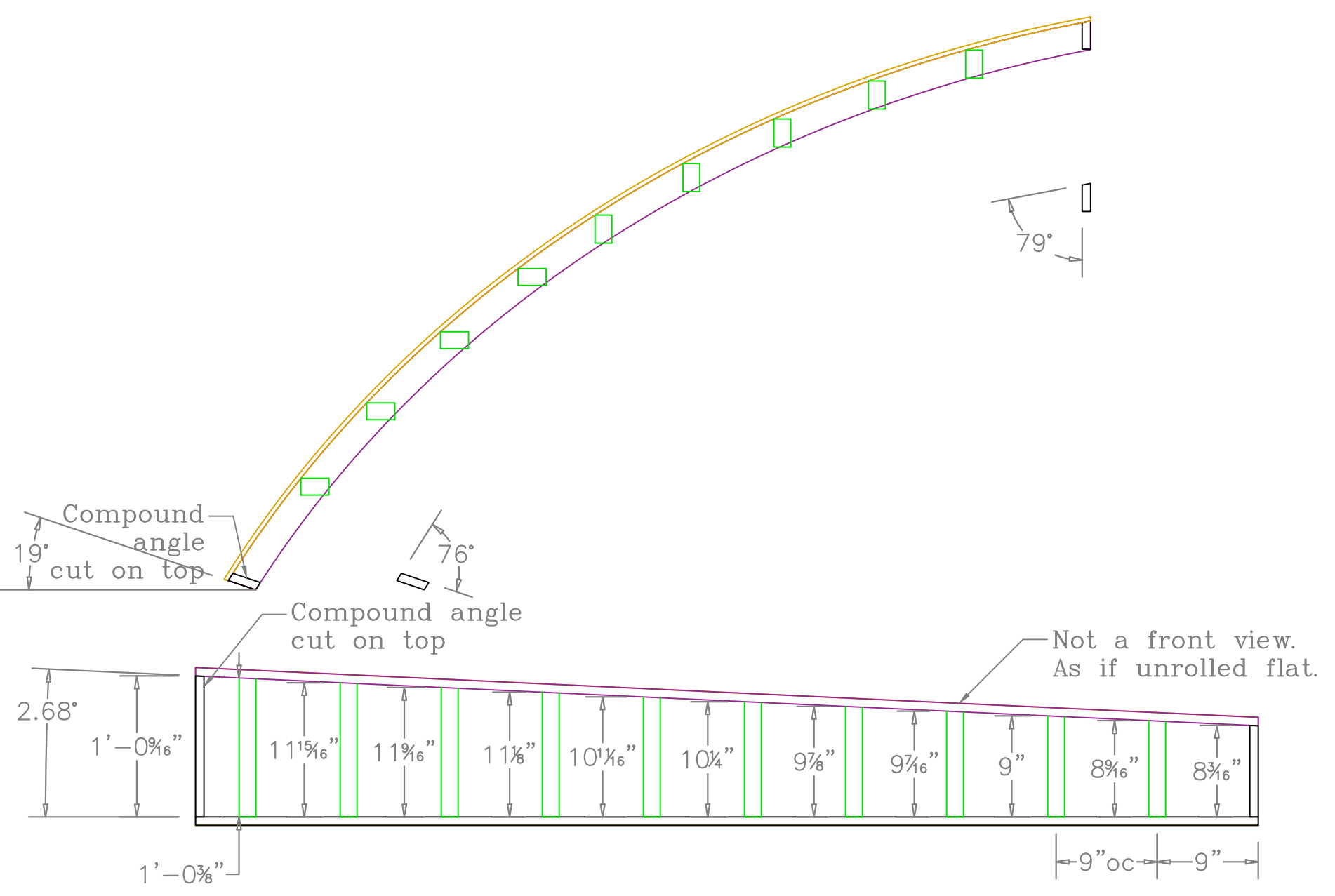

1 Platforms B1 Facing Wall  
1" = 1'-0"

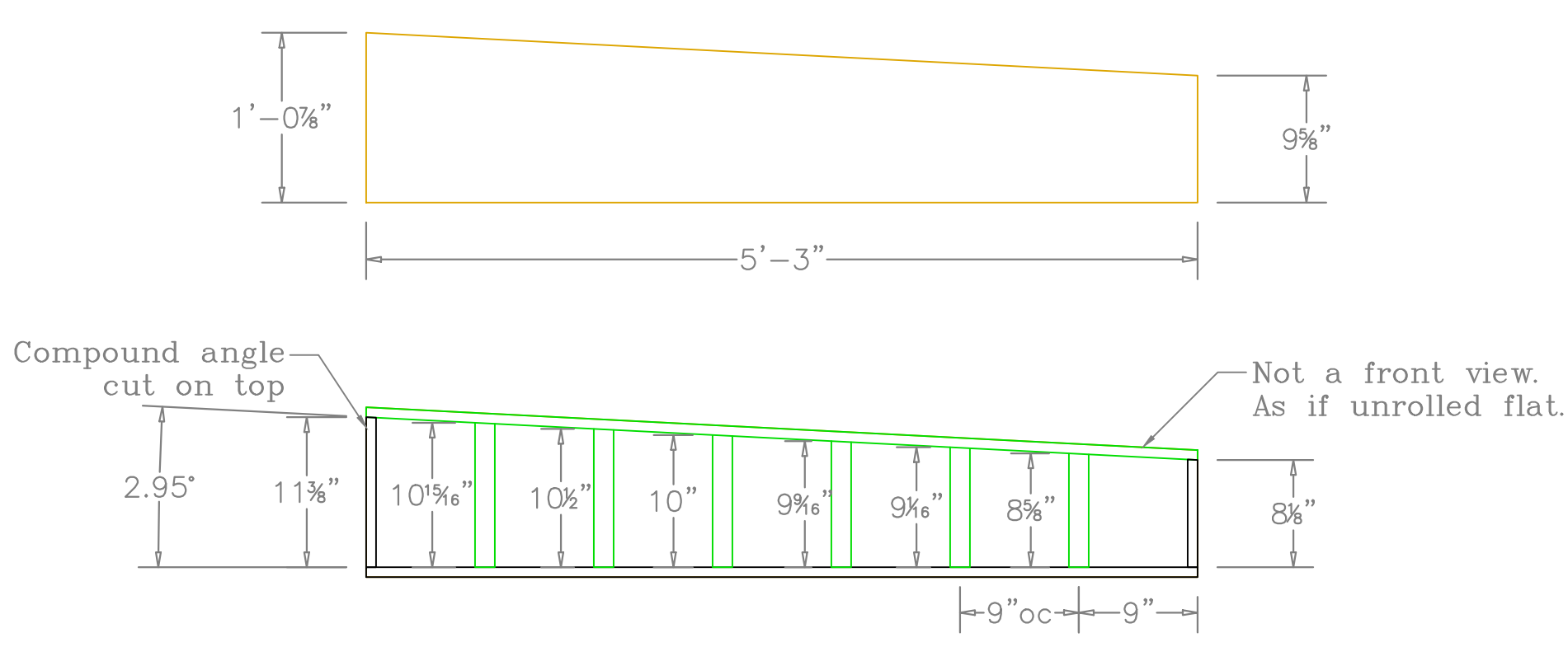

5 Platforms B5 Facing Wall  
1" = 1'-0"

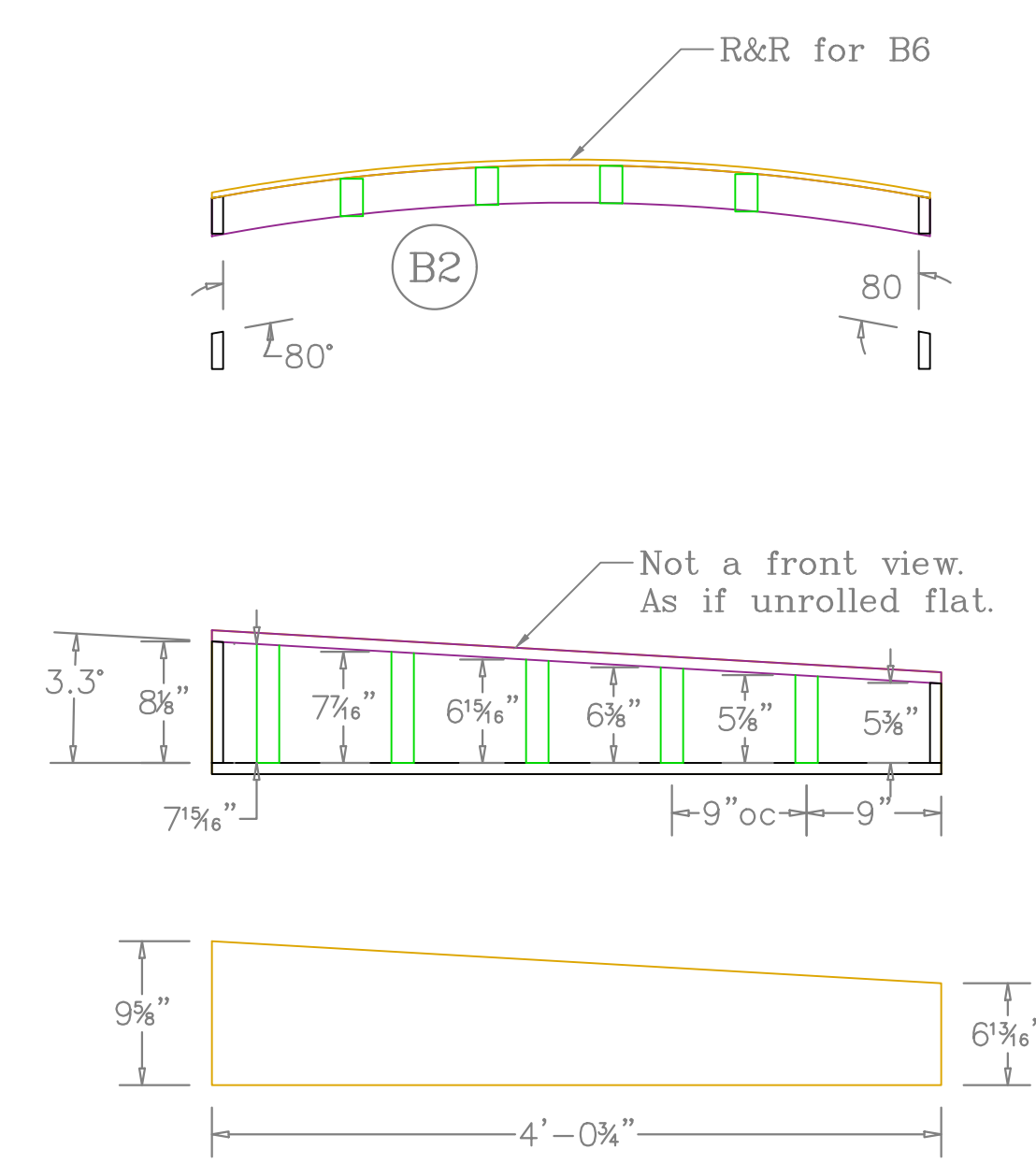

2 Platforms B2 Facing Wall  
1" = 1'-0"

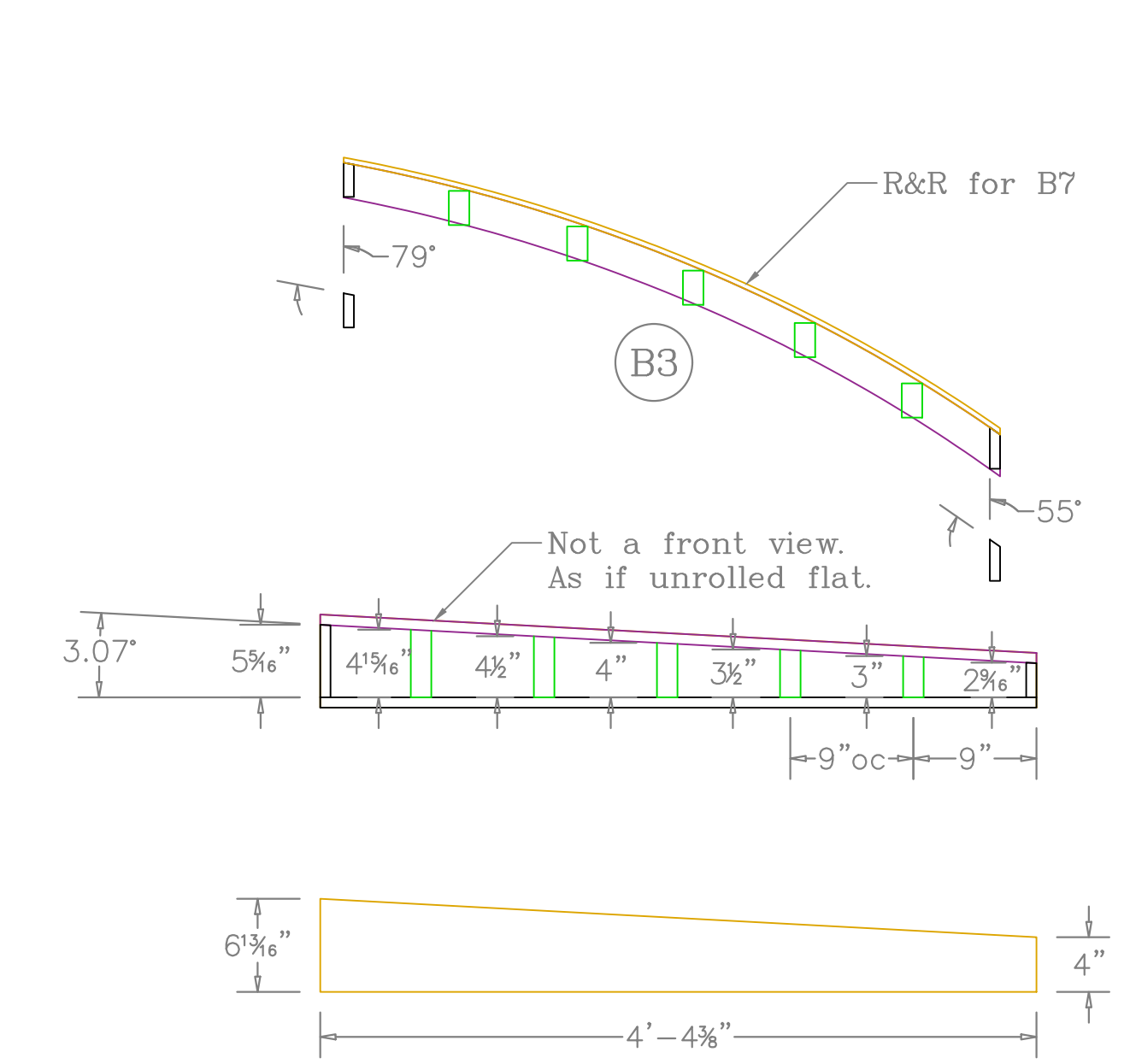

3 Platforms B3 Facing Wall  
1" = 1'-0"

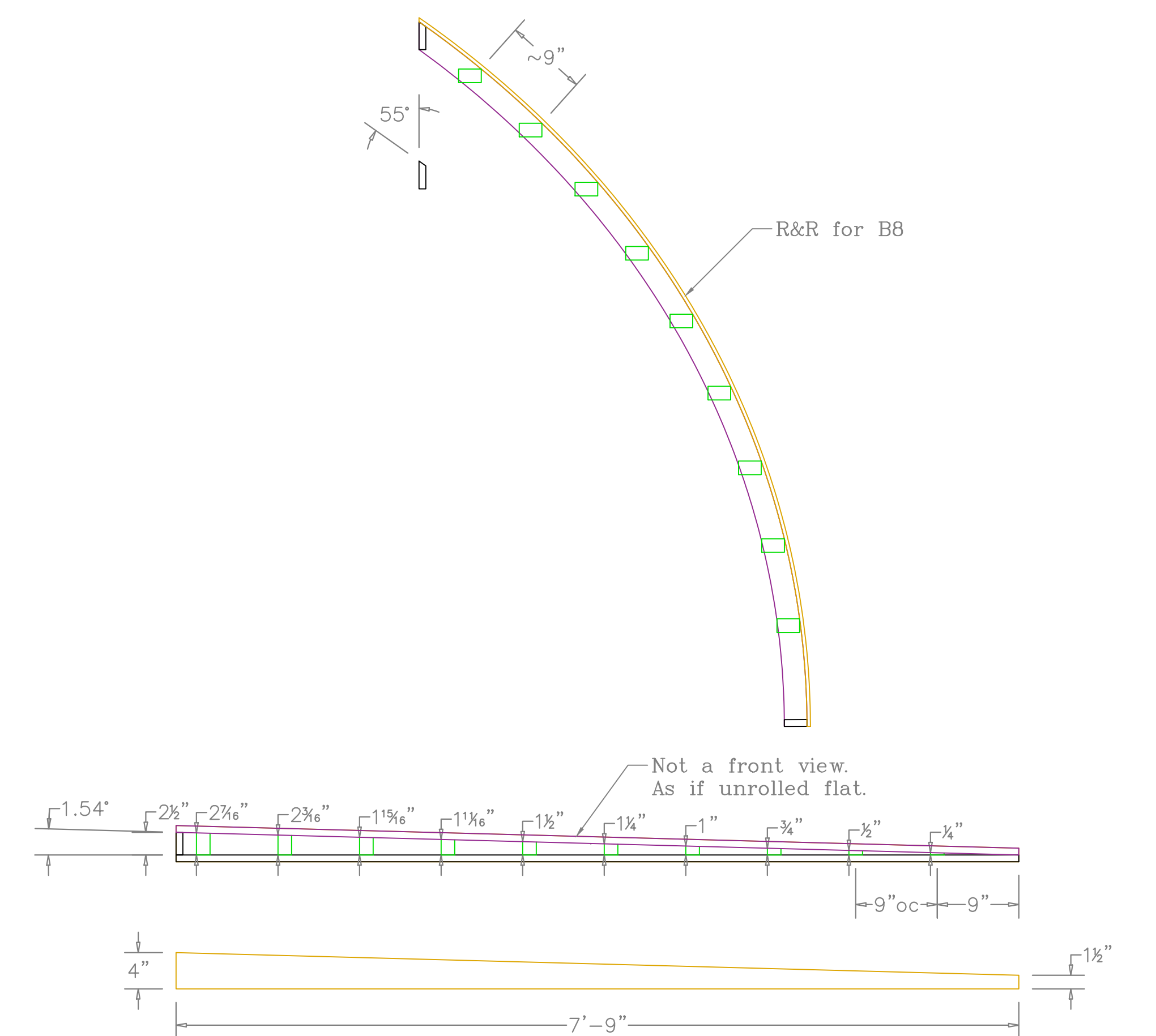

4 Platforms B4 Facing Wall  
1" = 1'-0"

Notes:  
 +Lumber: 3/8" bendi ply shown here in tan. 2x4 in green. 3/4" ply in black. Purple is the top rail but is also 3/4" ply.  
 +The bendi ply that is dimensioned is shown as if unrolled flat.  
 +The front framing view of the wall is also shown as if it was unrolled flat.  
 +All interior vertical framing members align with the rake angle and are either parallel or perpendicular to it so that they each only need one angle cut in their tops. Two framing members will need compound angles on their tops - these are on Platforms B1 & B5.

8	Platform B - Facing Walls	American Players Theatre 2023	Scale: 1" = 1'-0"	Director: Laura Rook	TD: Bill Duwell.
	Production: Once Upon a Bridge		Date: 4/28/2023	Scenic Design: Lawrence Moten	ATD: Doug Dion

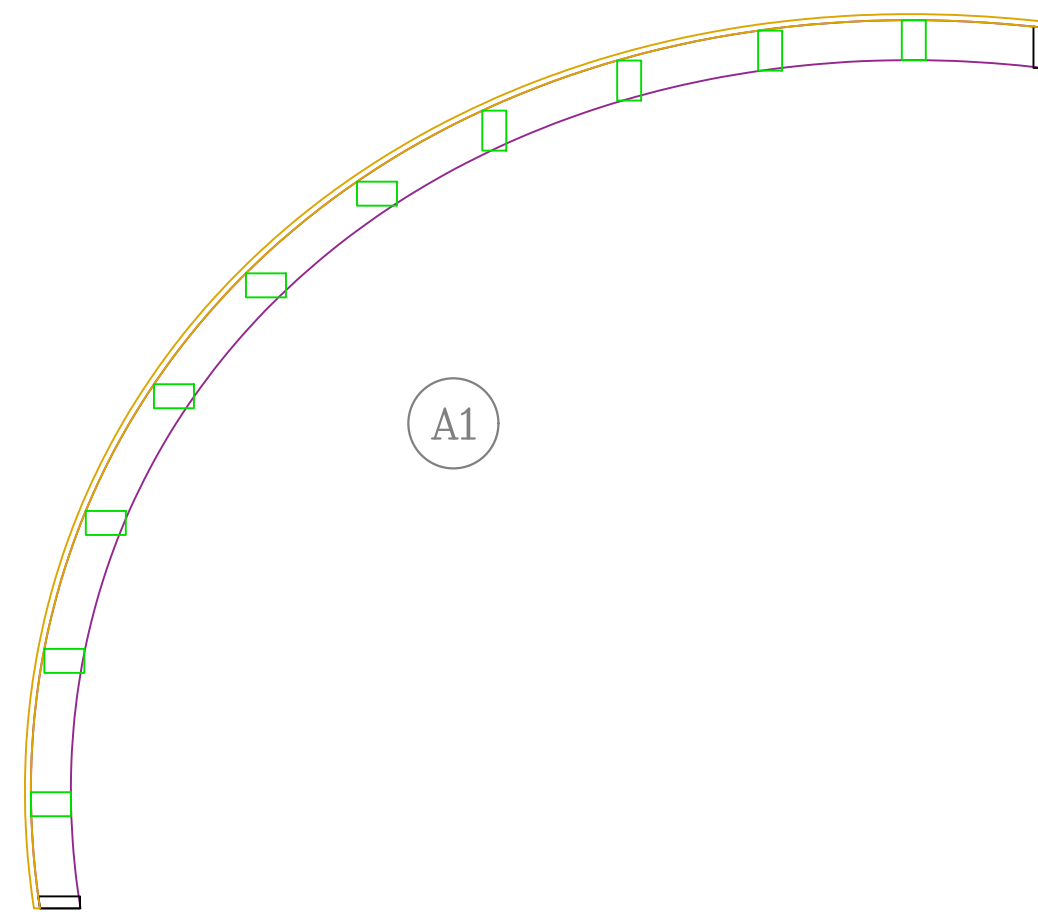

A1

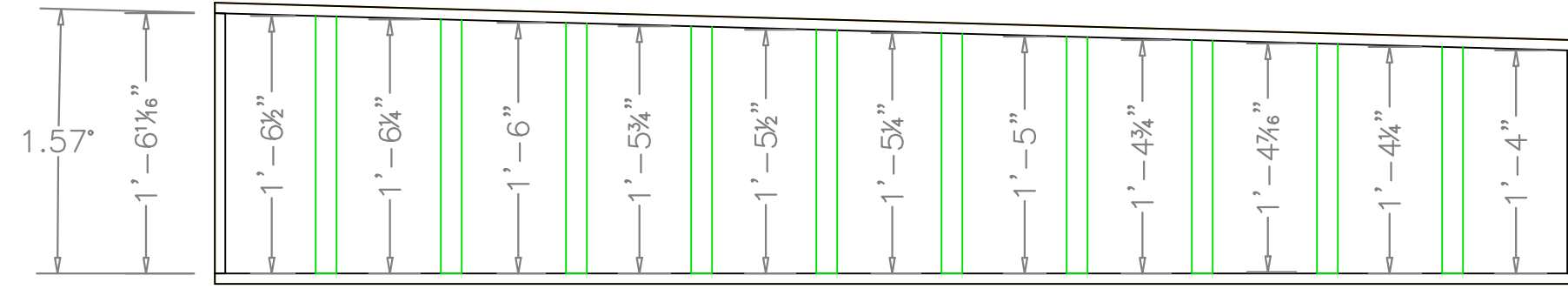

Notes:  
 +Lumber: 3/8" bendi ply shown here in tan. 2x4 in green. 3/4" ply in black. Purple is the top rail but is also 3/4" ply.  
 +The bendi ply that is dimensioned is shown as if unrolled flat.  
 +The front framing view of the wall is also shown as if it was unrolled flat.  
 +All interior vertical framing members align with the rake angle and are either parallel or perpendicular to it so that they each only need one angle cut in their tops. Two framing members will need compound angles on their tops - these are on Platforms B1 & B5.

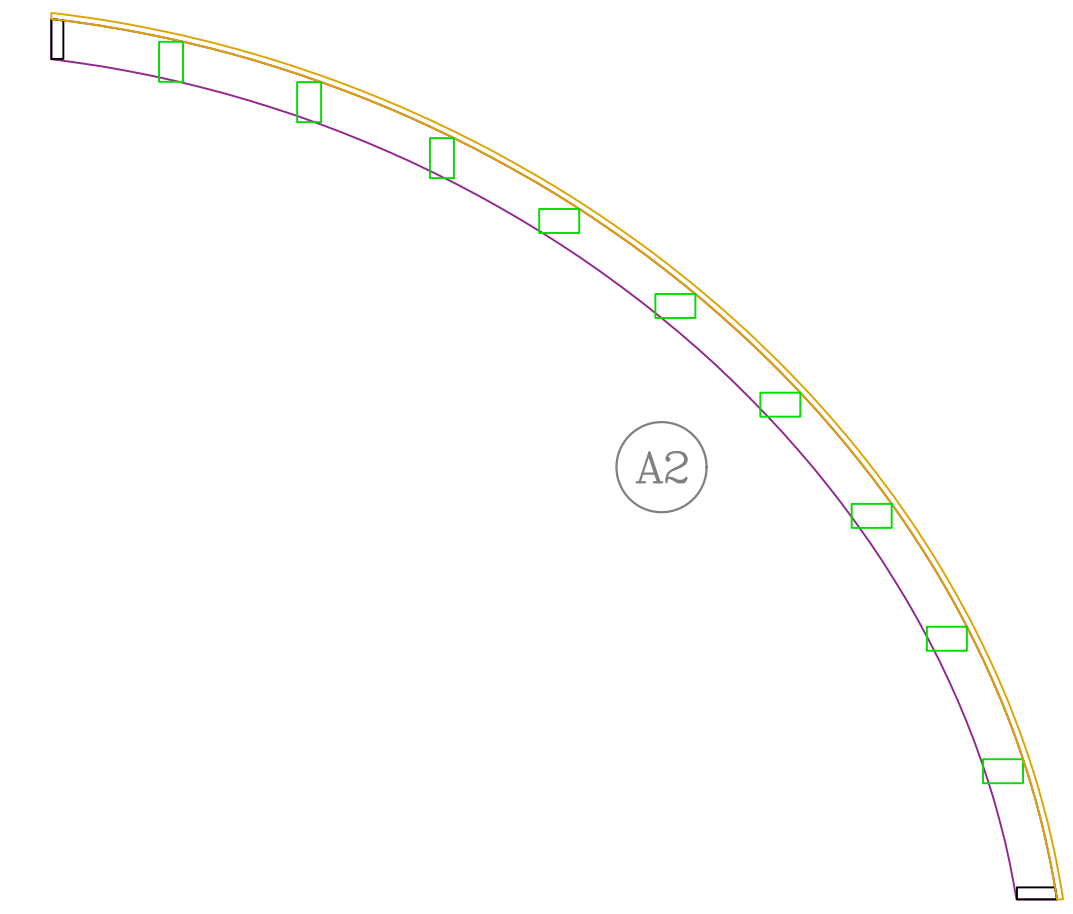

A2

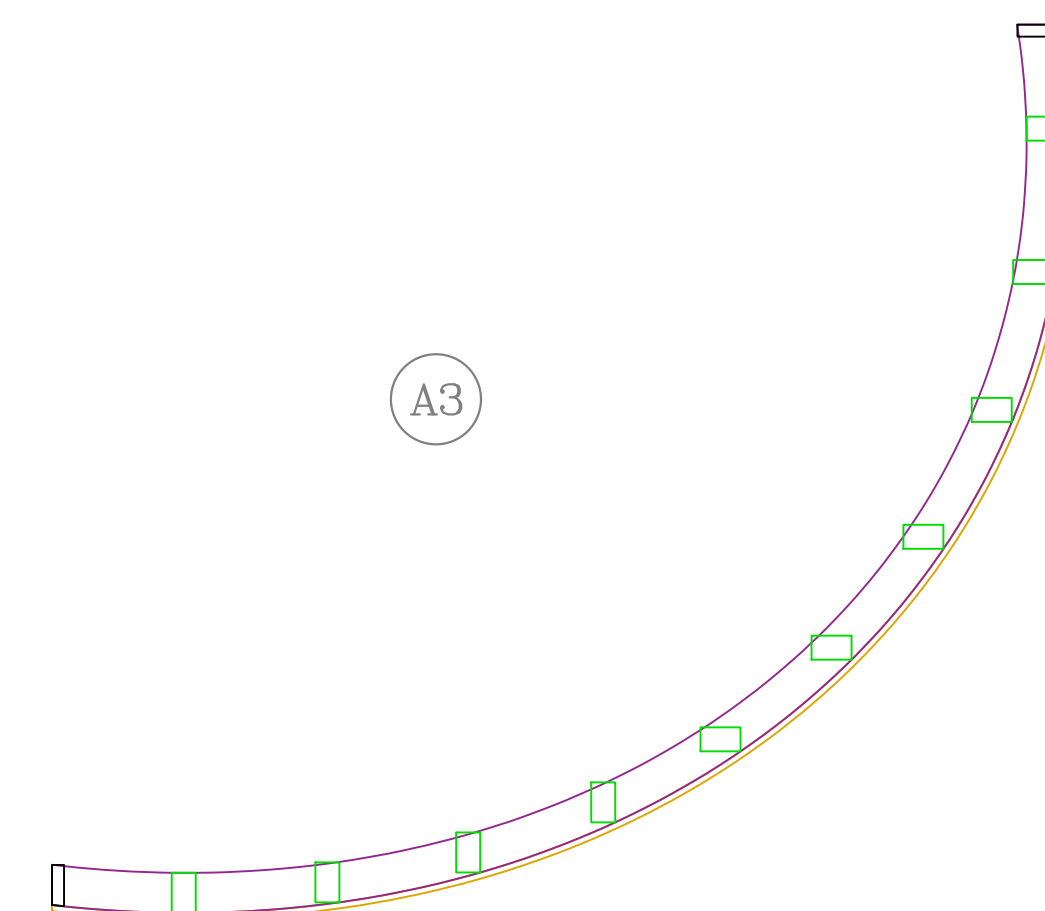
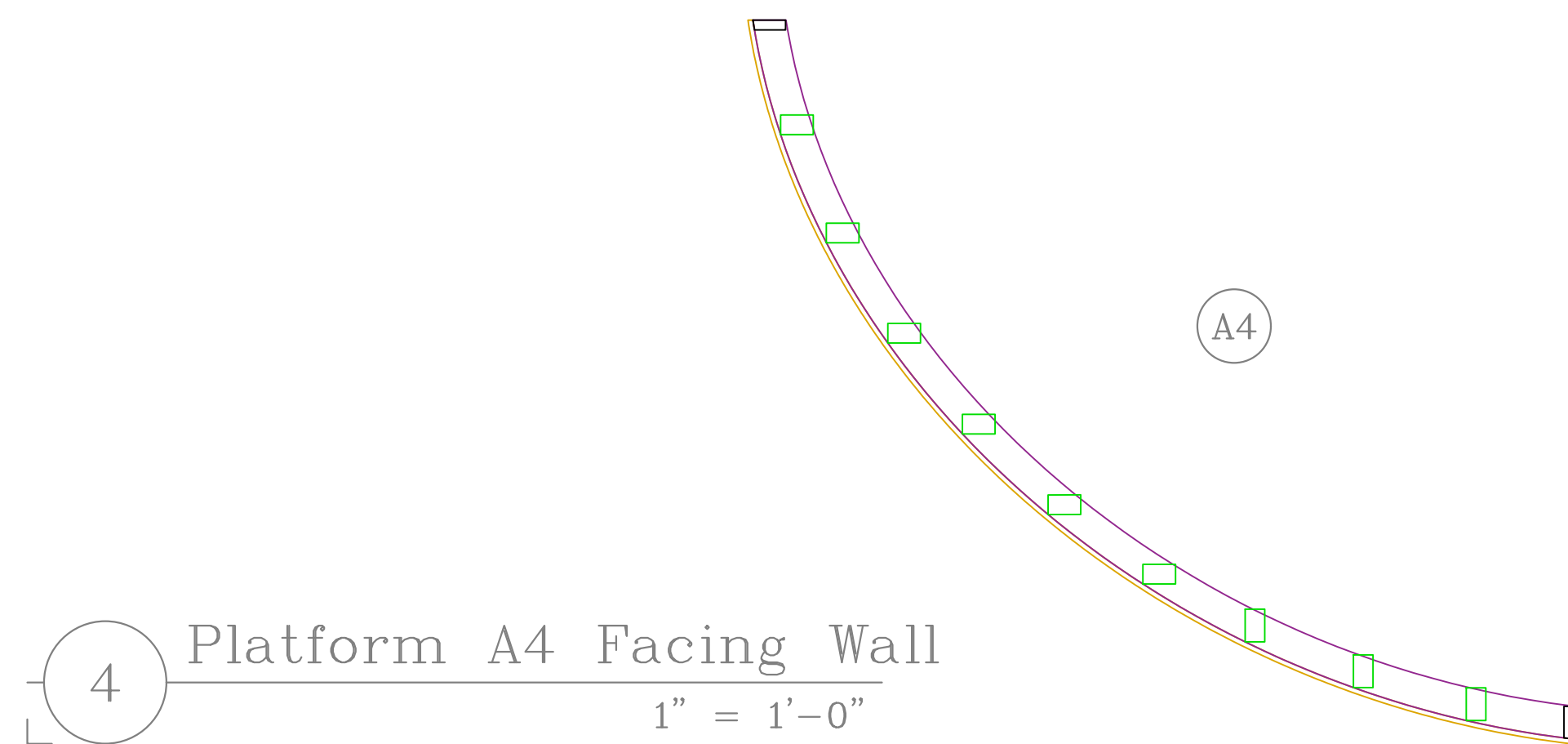
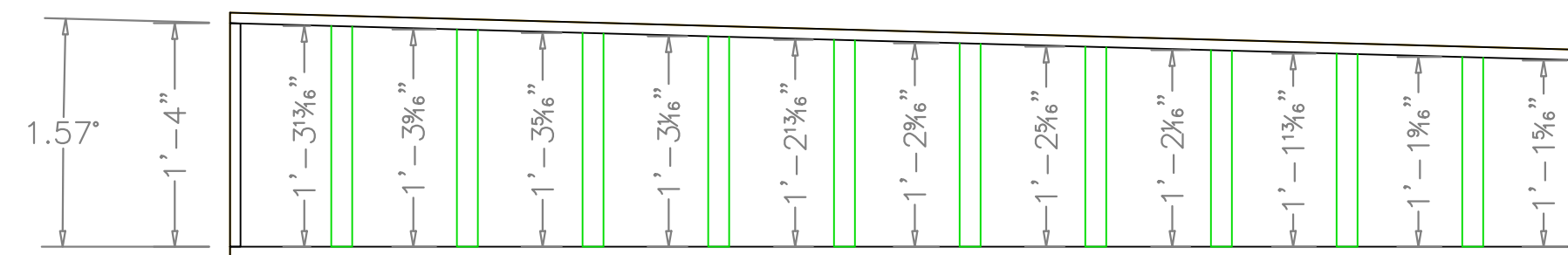
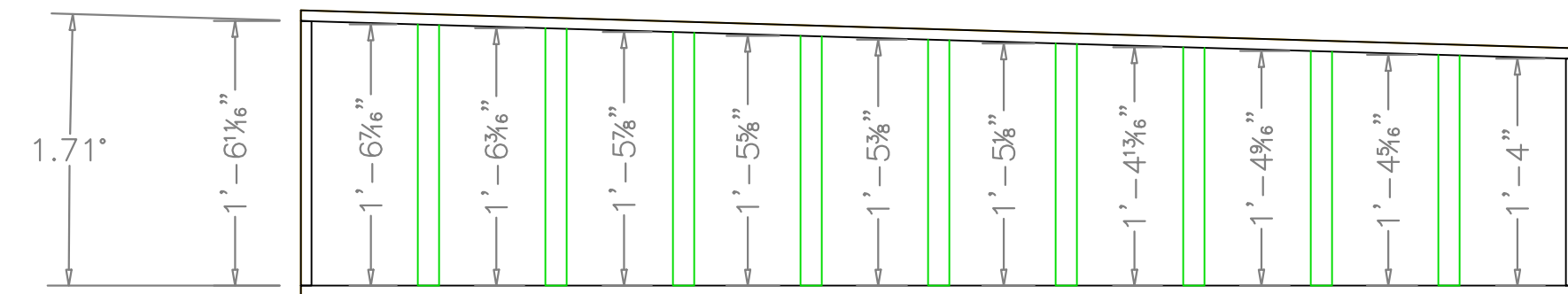
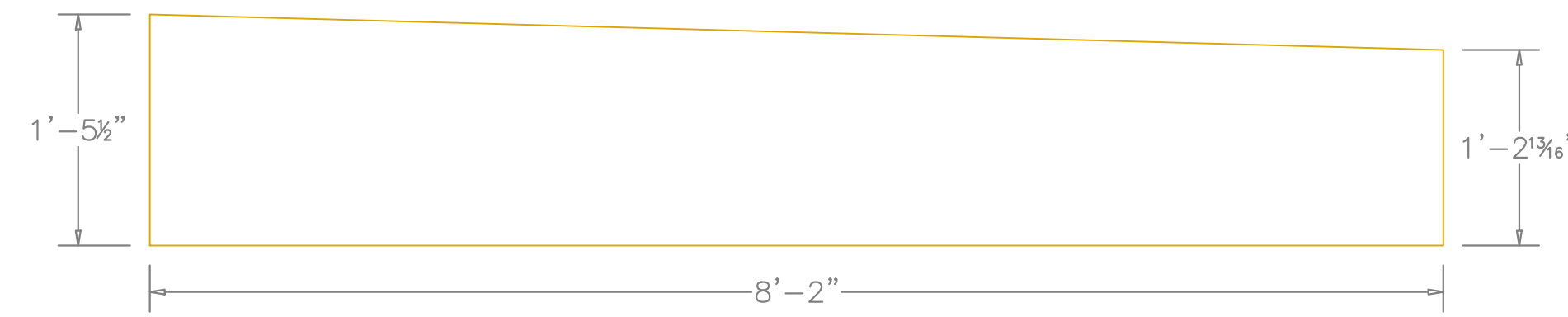
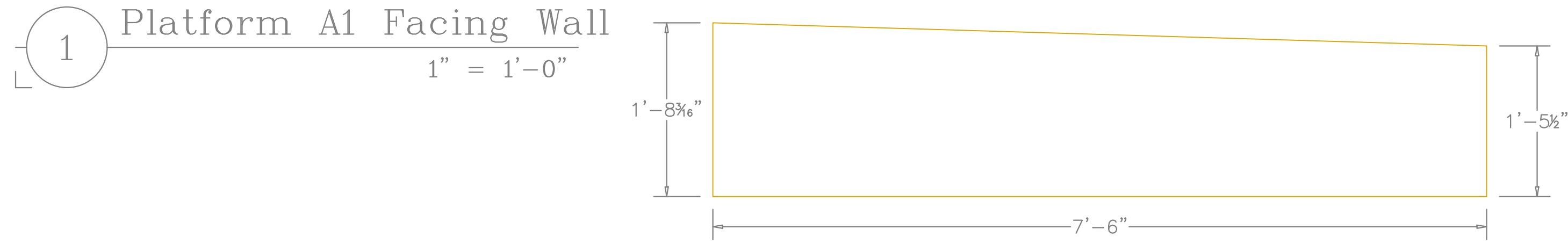
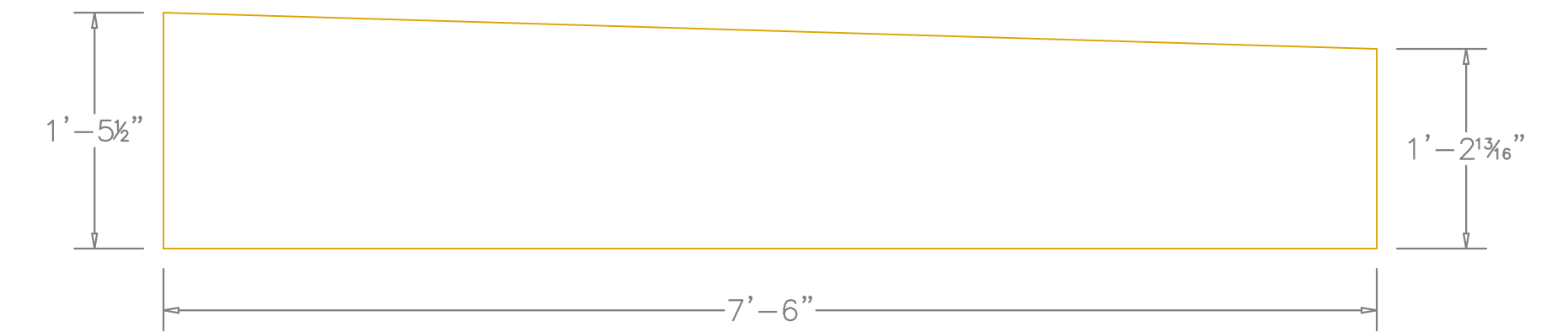
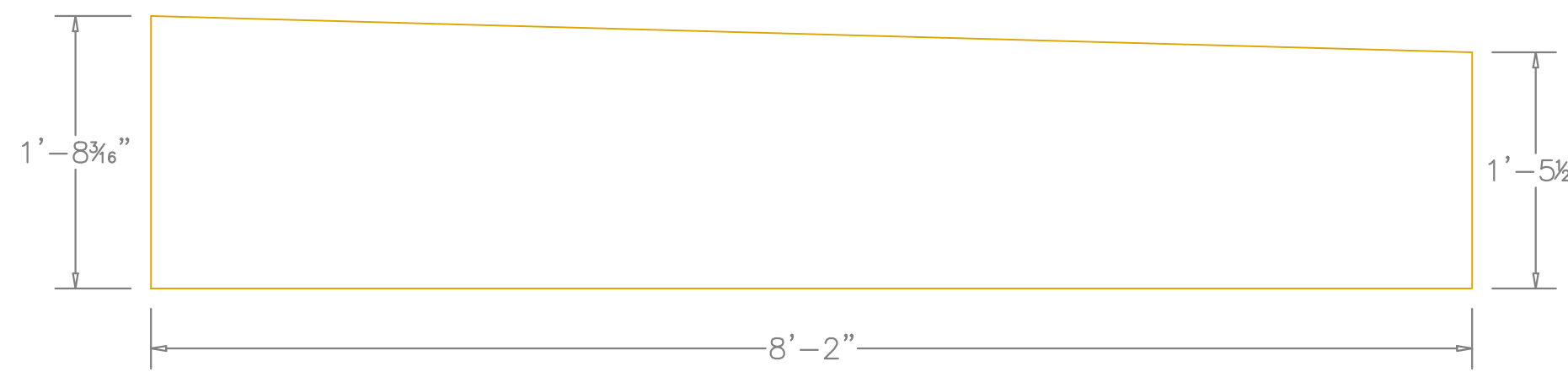
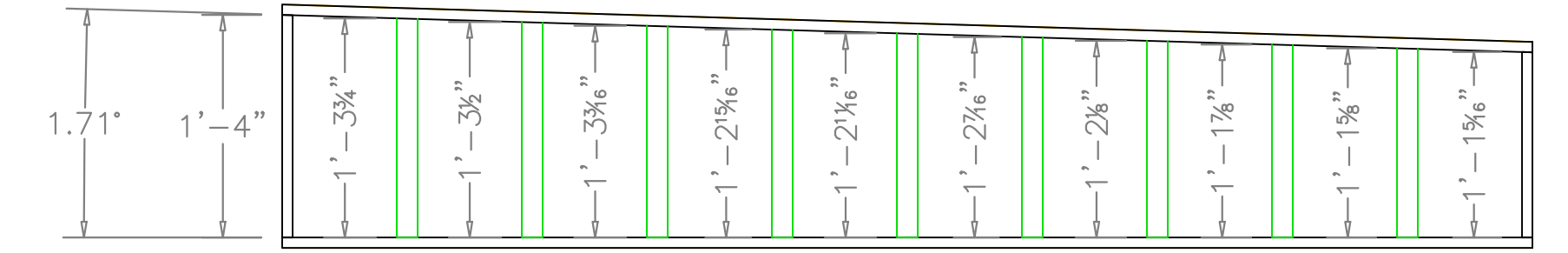

9	Platform A - Facing Walls	American Players Theatre 2023	Scale: 1" = 1'-0"	Director: Laura Rook	TD: Bill Duwell.
	Production: Once Upon a Bridge		Date: 4/28/2023	Scenic Design: Lawrence Moten	ATD: Doug Dion

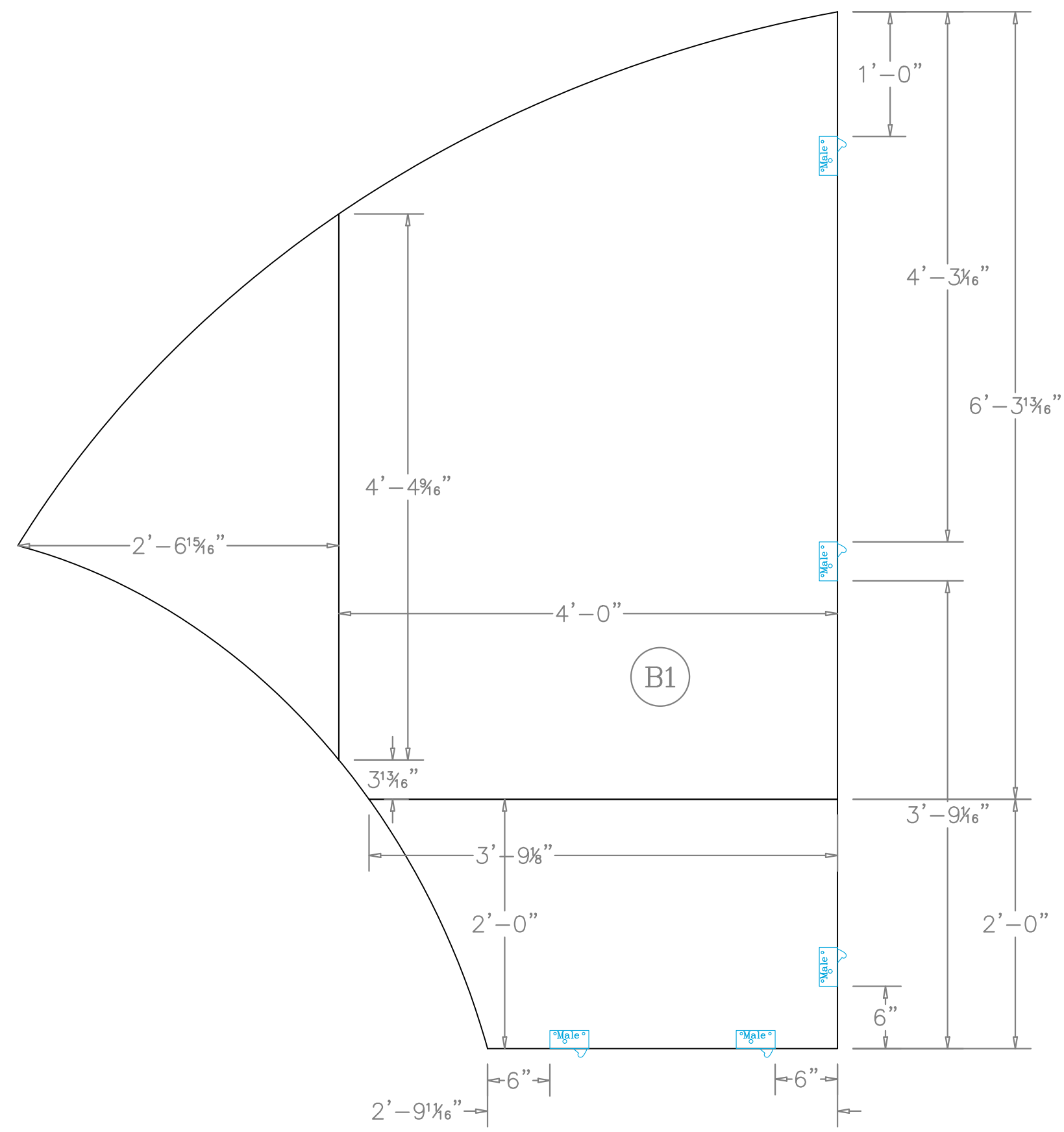

1 Platform B1 Top View  
1" = 1'-0"

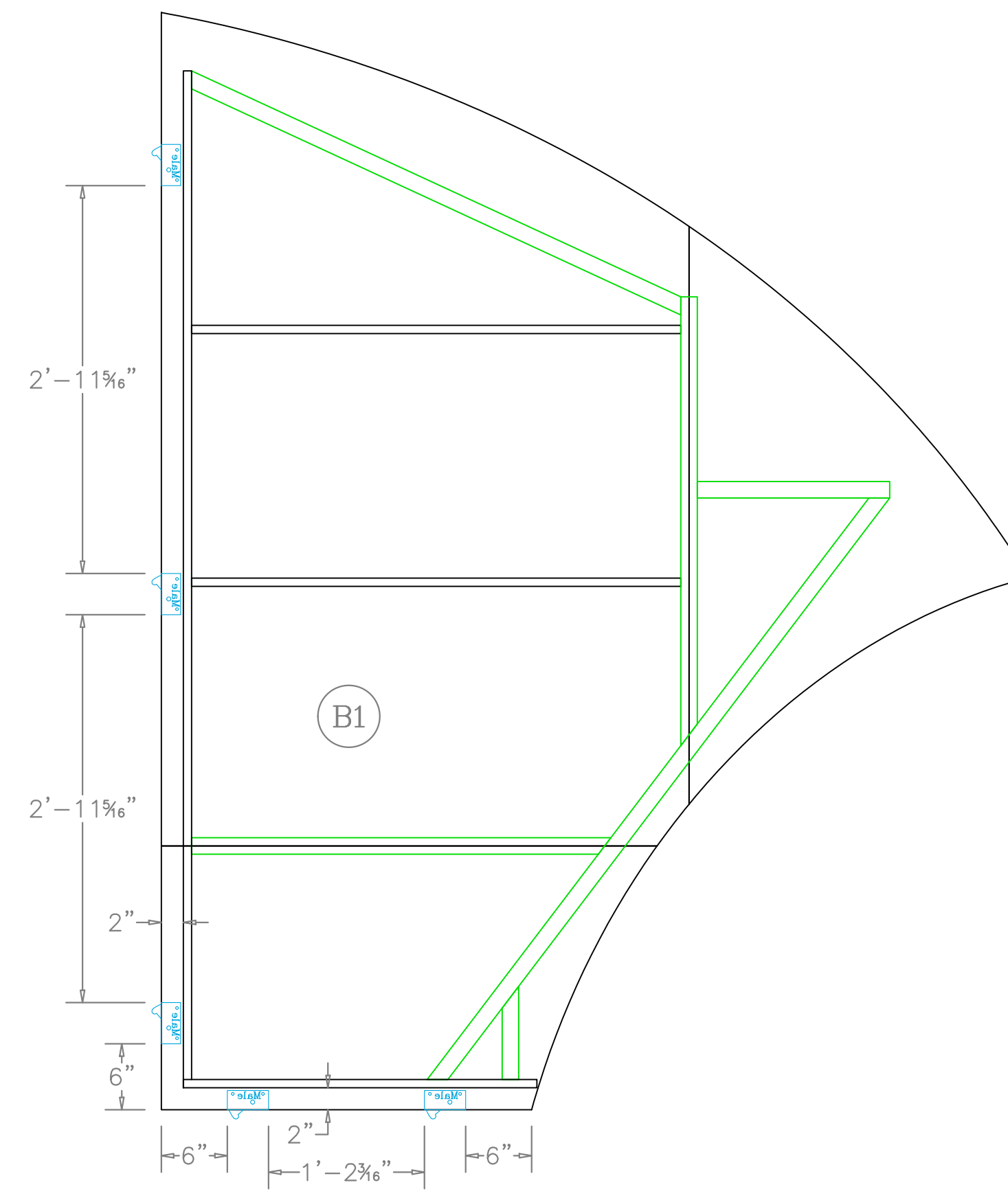

2 Platform B1 Bottom View  
1" = 1'-0"

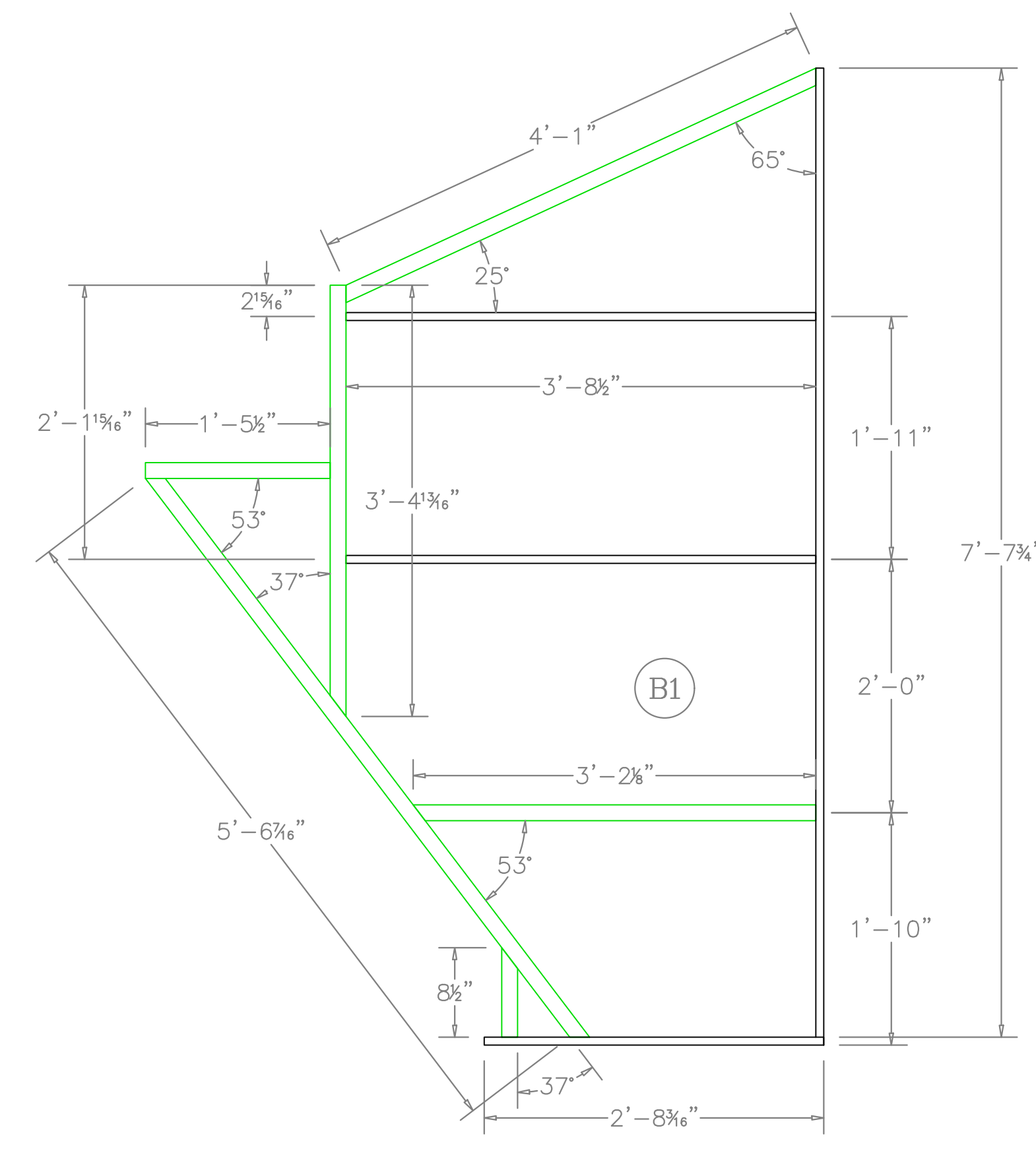

3 Platform B1 Top View - Framing  
1" = 1'-0"

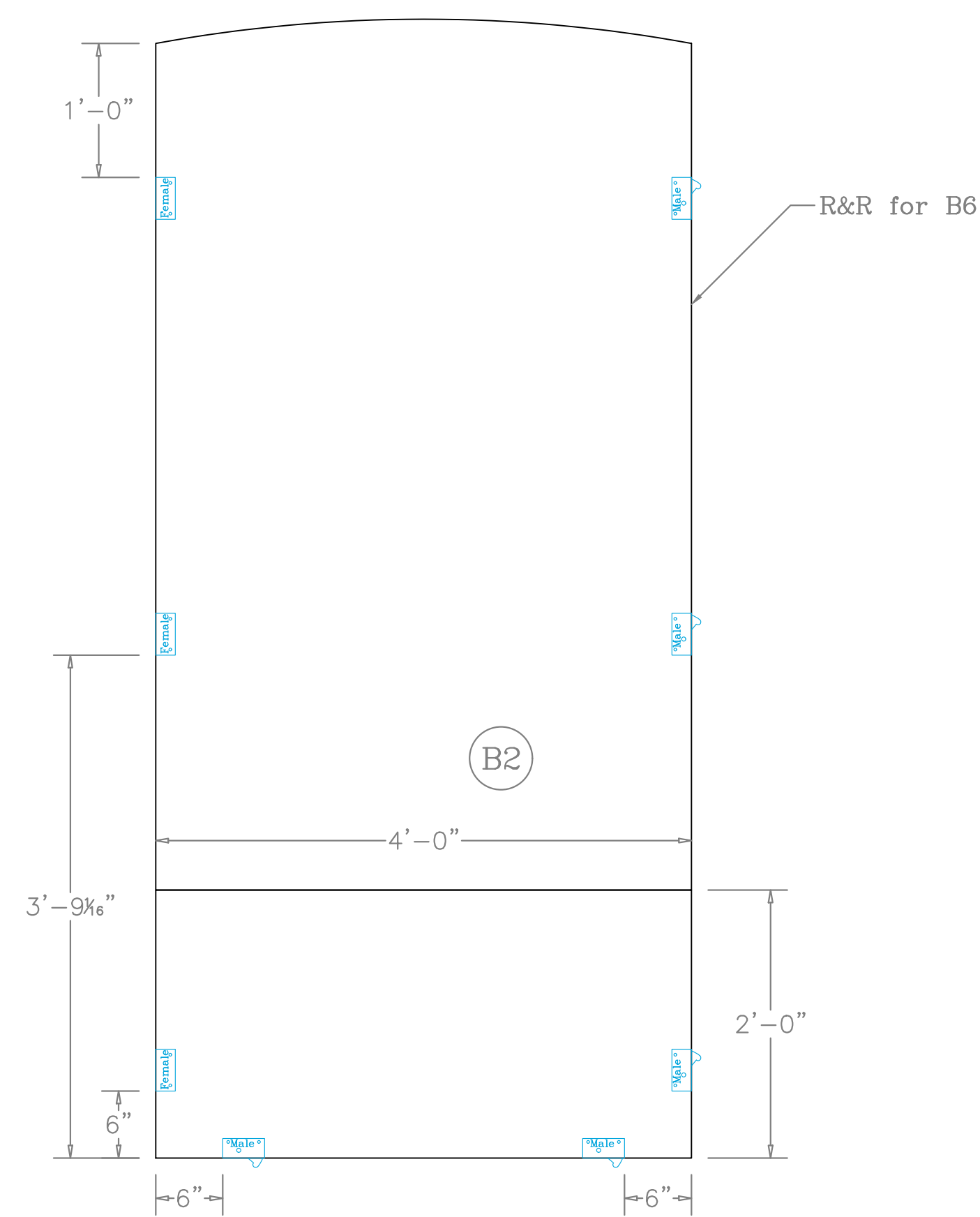

4 Platform B2 Top View  
1" = 1'-0"

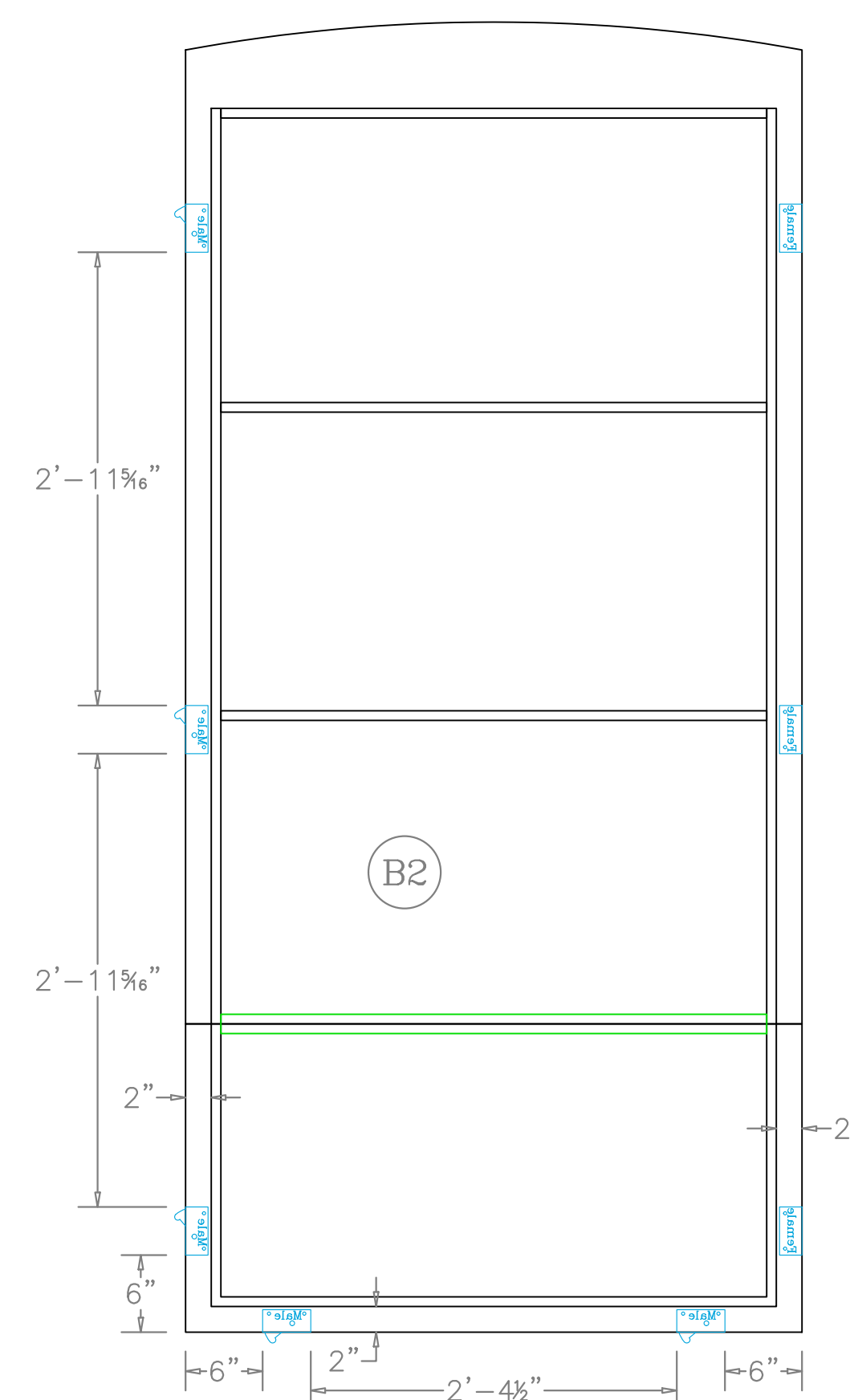

5 Platform B2 Bottom View  
1" = 1'-0"

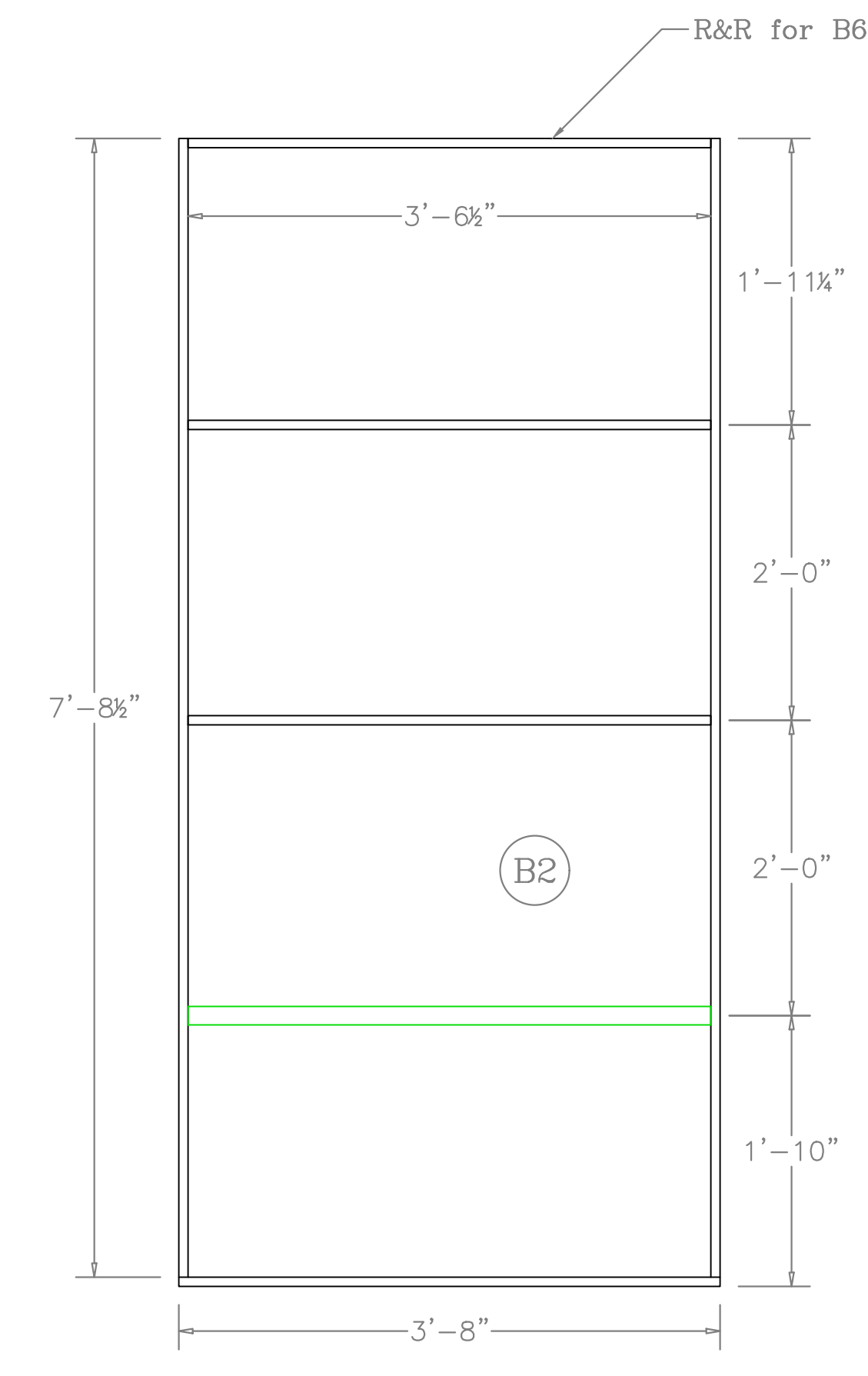

6 Platform B2 Top View - Framing  
1" = 1'-0"

Notes:  
 +Lumber: 2x4 is shown here in green. 3/4" ply in black.  
 +All framing is ripped to 3-1/2" except where otherwise noted. 2x4 can remain at full size.  
 +Curved lids and framing have already been cut from our order with the CNC shop, but some more regularly sized lids may need to be cut still.  
 +Glue and screw all framing. Glue and screw lids to framing.  
 +Fill and sand all screw holes.  
 +Sorry for all the weird shapes

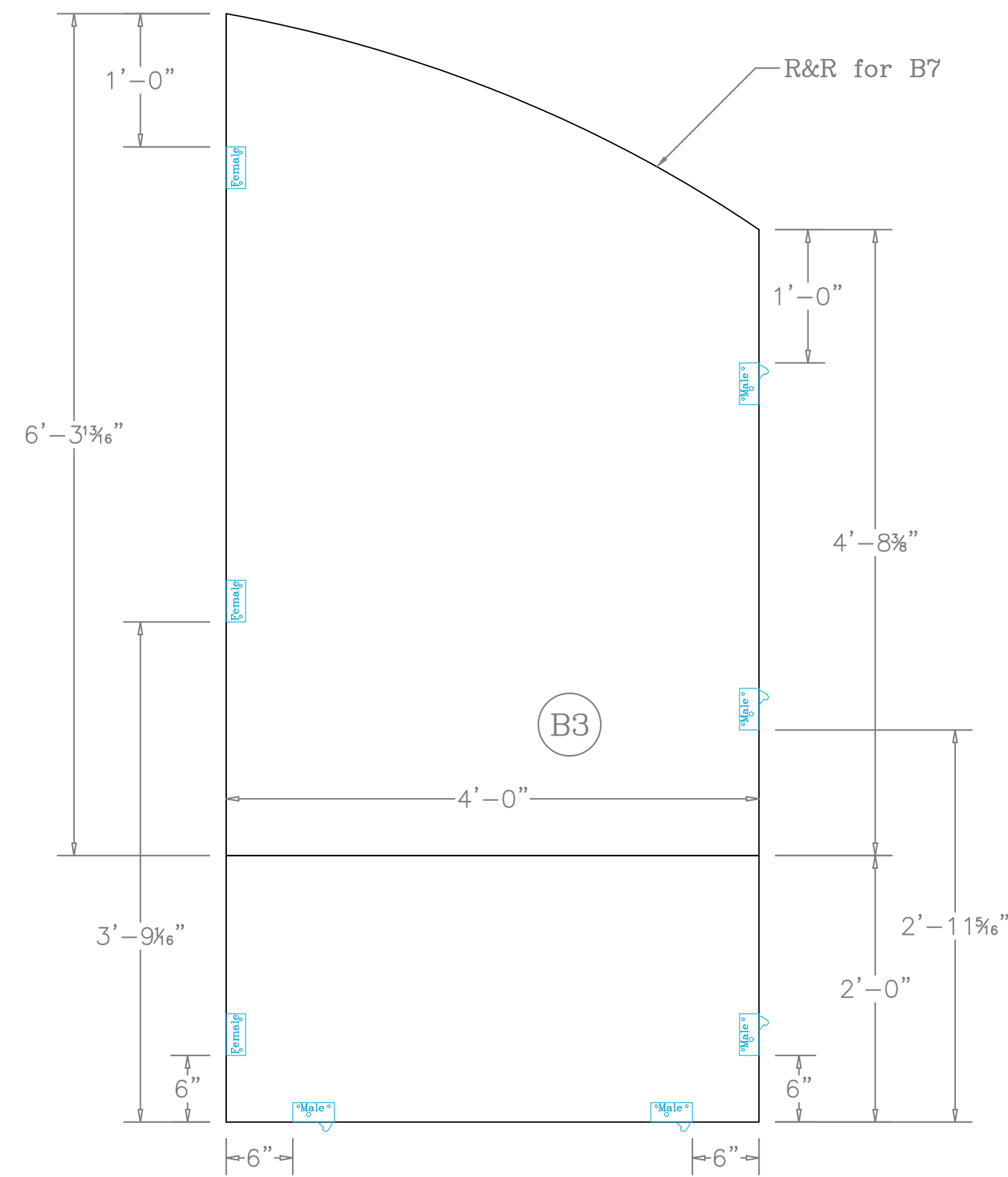

1 Platform B1 Top View  
1" = 1'-0"

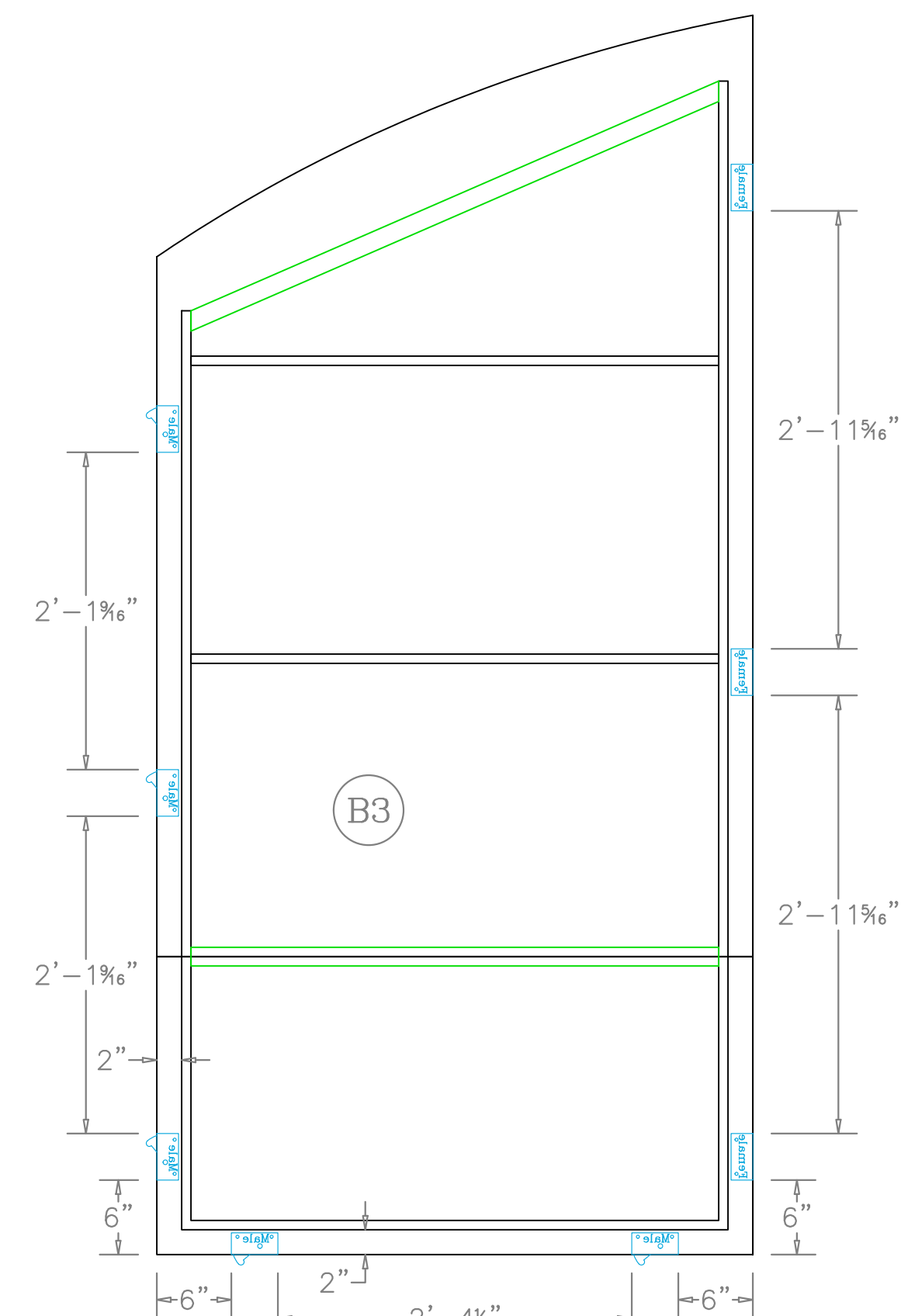

2 Platform B1 Bottom View  
1" = 1'-0"

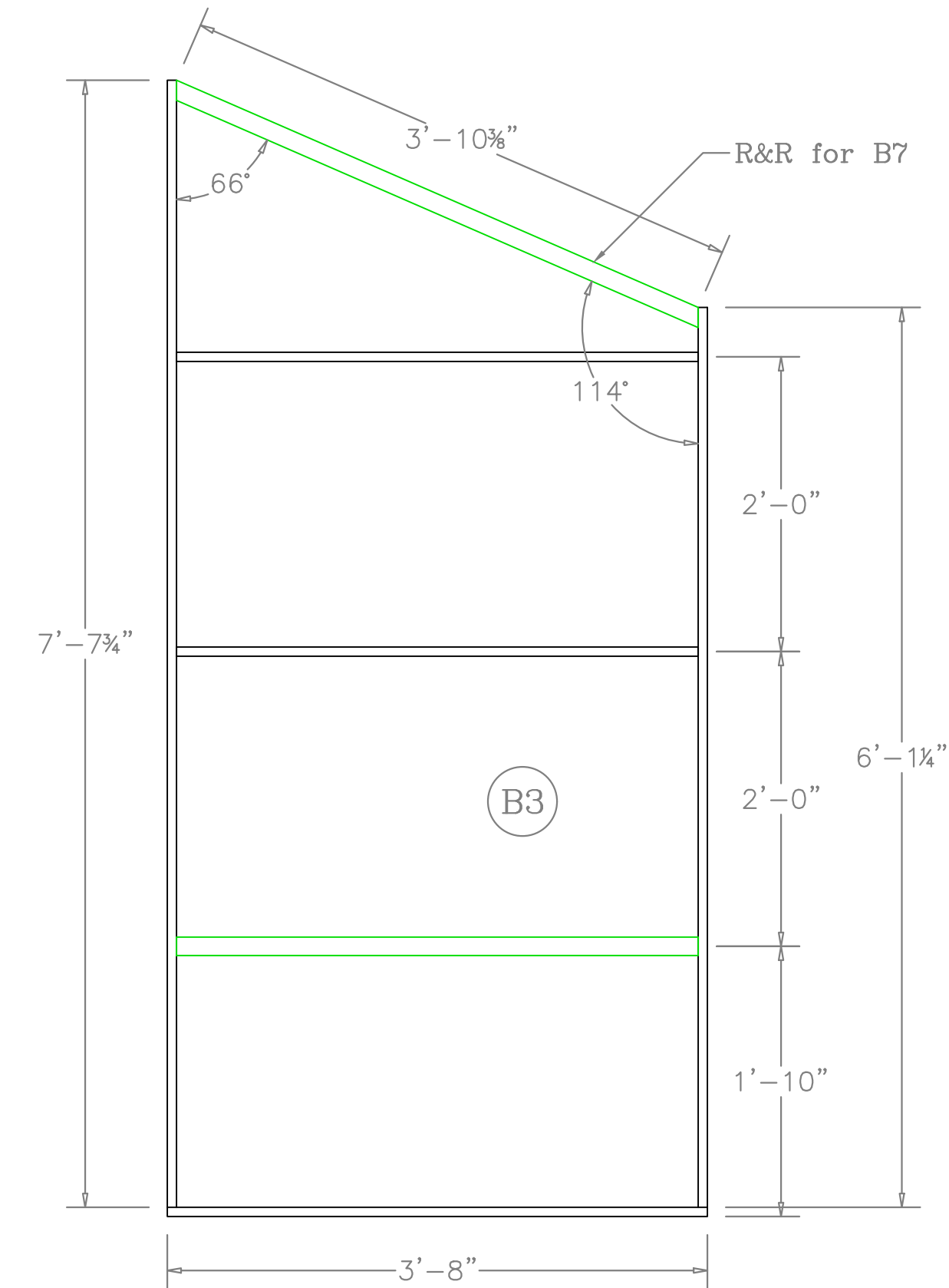

3 Platform B1 Top View - Framing  
1" = 1'-0"

Notes:  
 +Lumber: 2x4 is shown here in green. 3/4" ply in black.  
 +All framing is ripped to 3-1/2" except where otherwise noted. 2x4 can remain at full size.  
 +Curved lids and framing have already been cut from our order with the CNC shop, but some more regularly sized lids may need to be cut still.  
 +Glue and screw all framing. Glue and screw lids to framing.  
 +Fill and sand all screw holes.  
 +Sorry for all the weird shapes

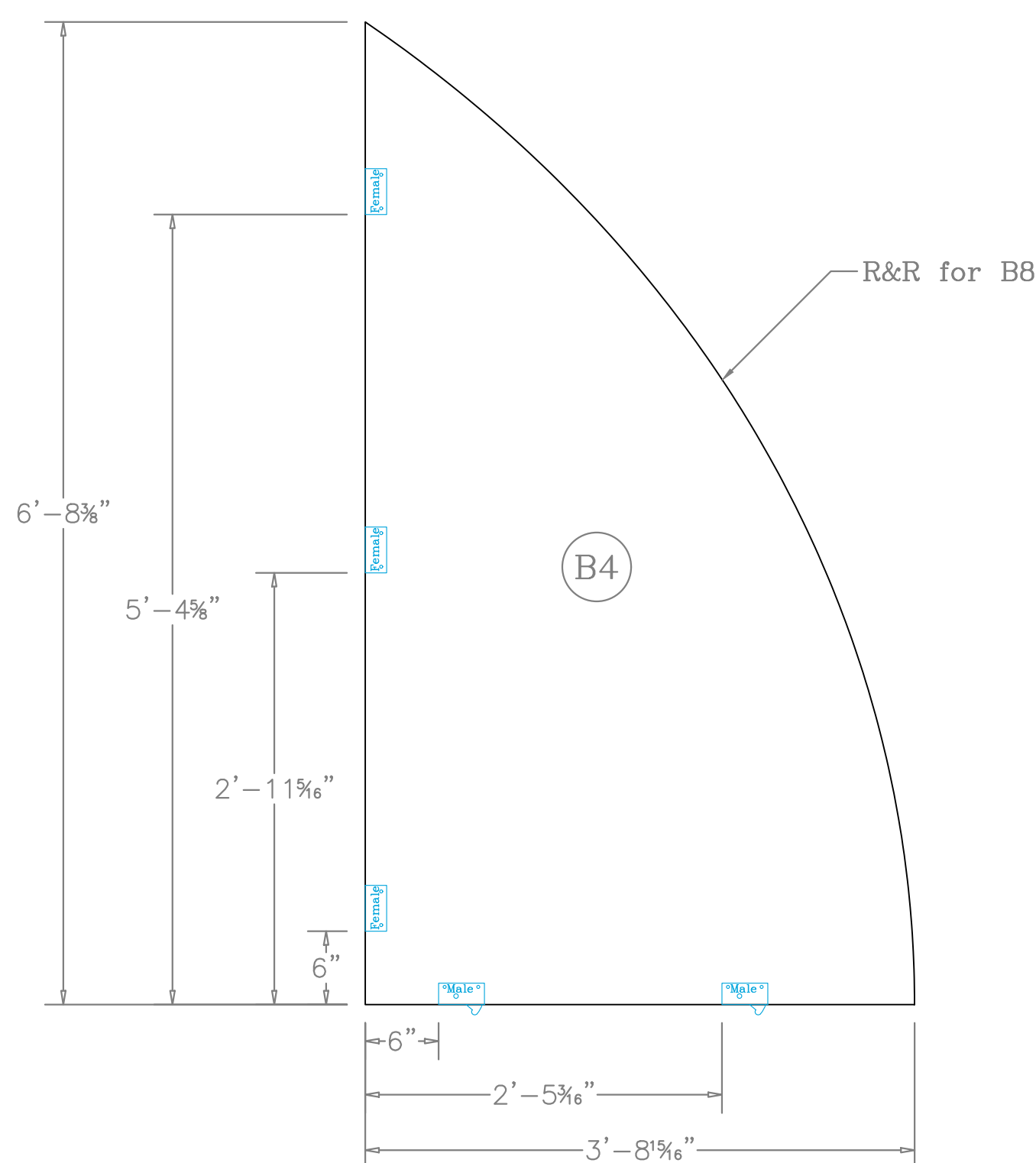

4 Platform B2 Top View  
1" = 1'-0"

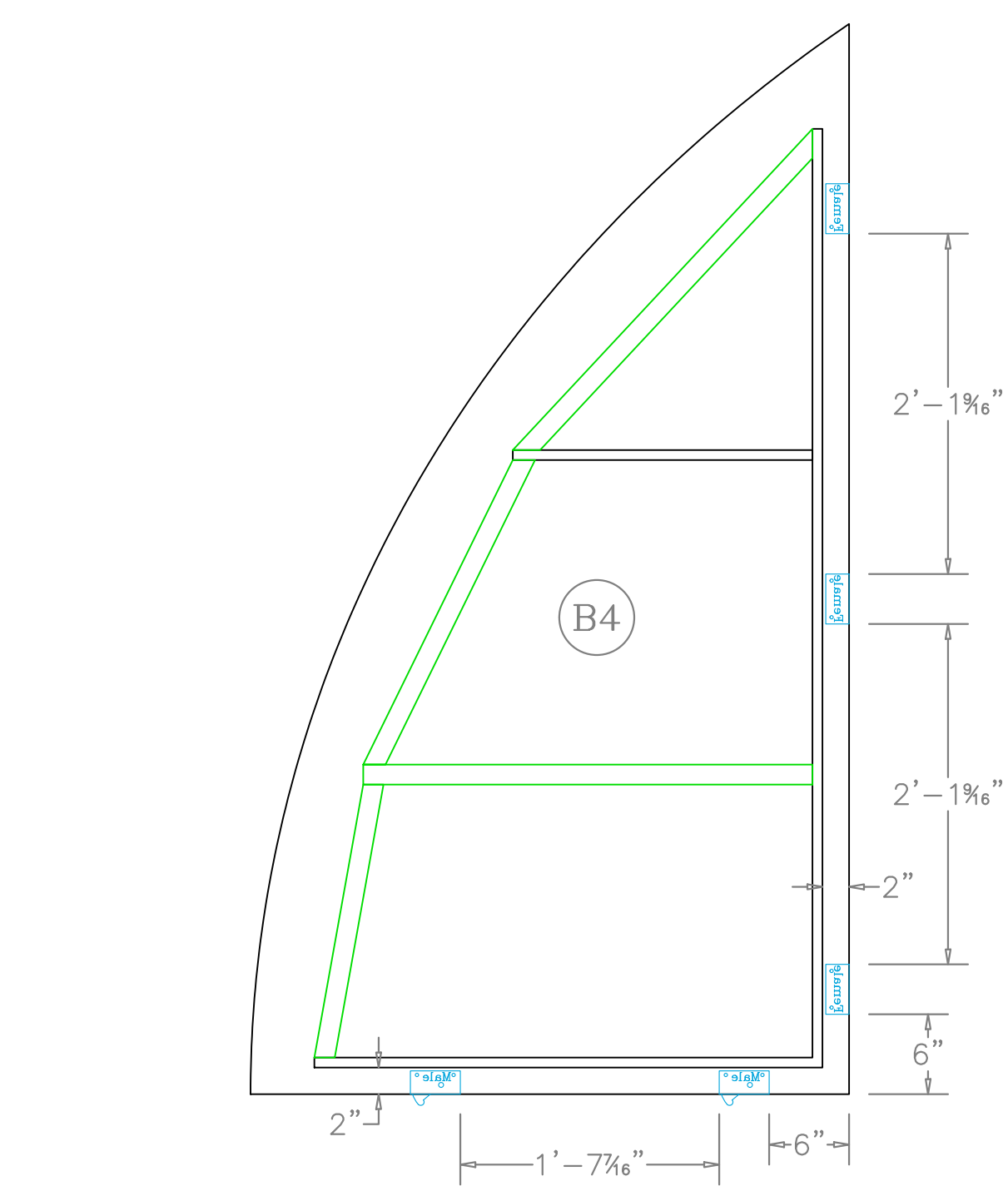

5 Platform B2 Bottom View  
1" = 1'-0"

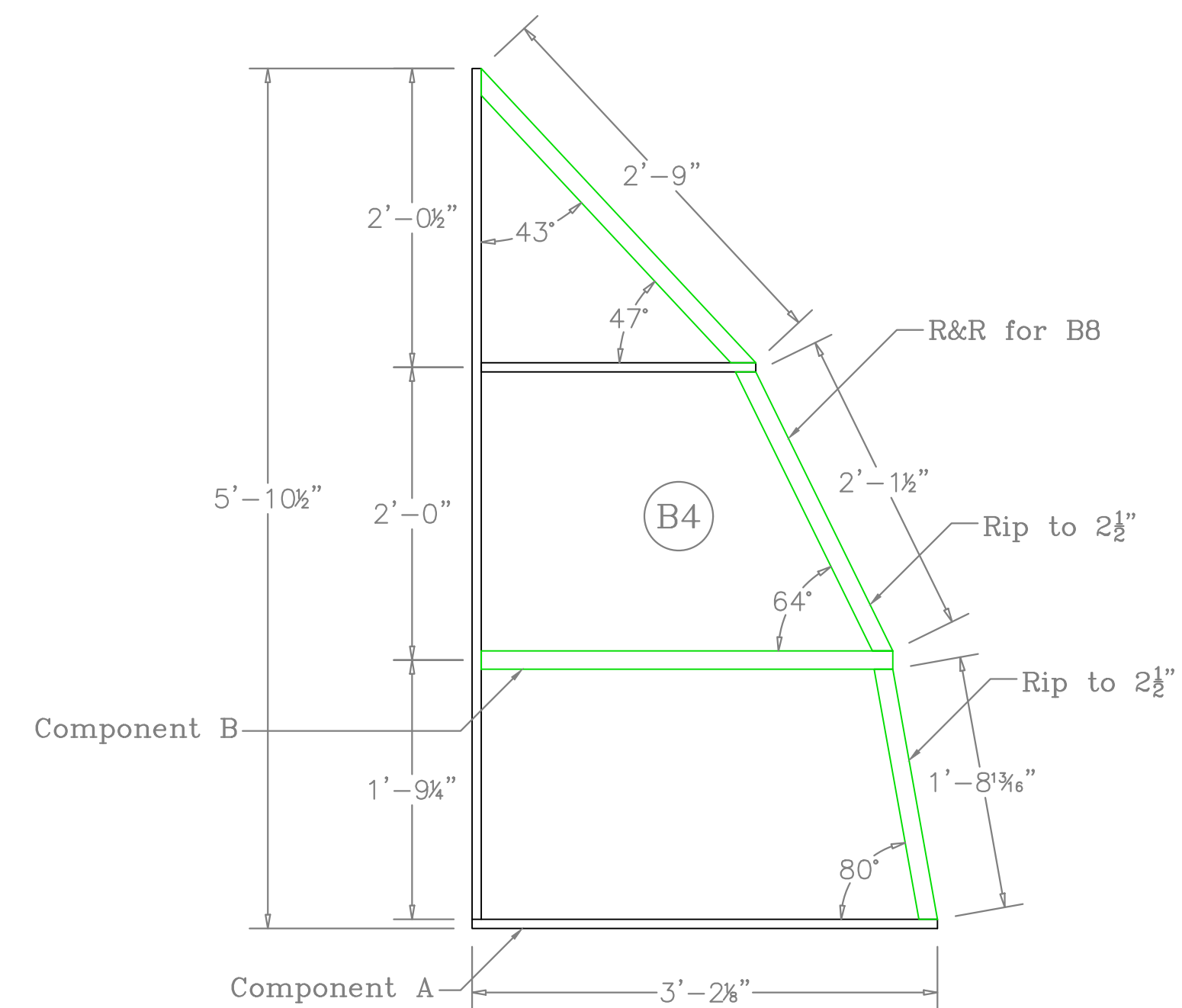

6 Platform B2 Top View - Framing  
1" = 1'-0"

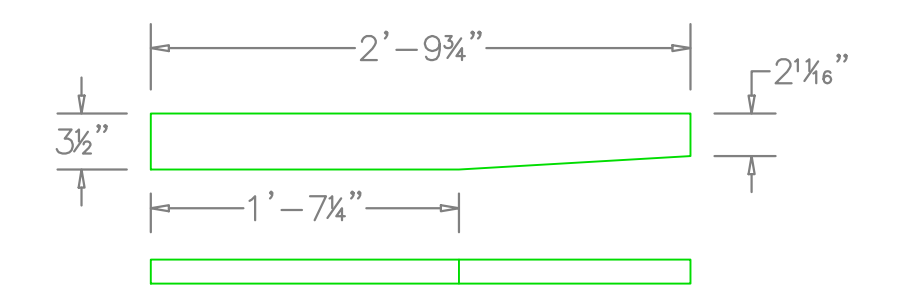

Component B

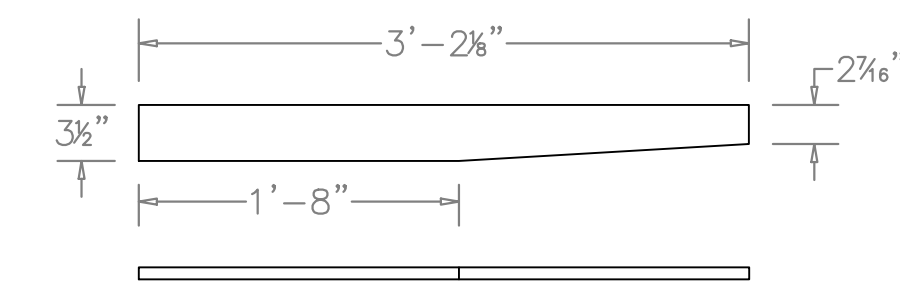

Component A

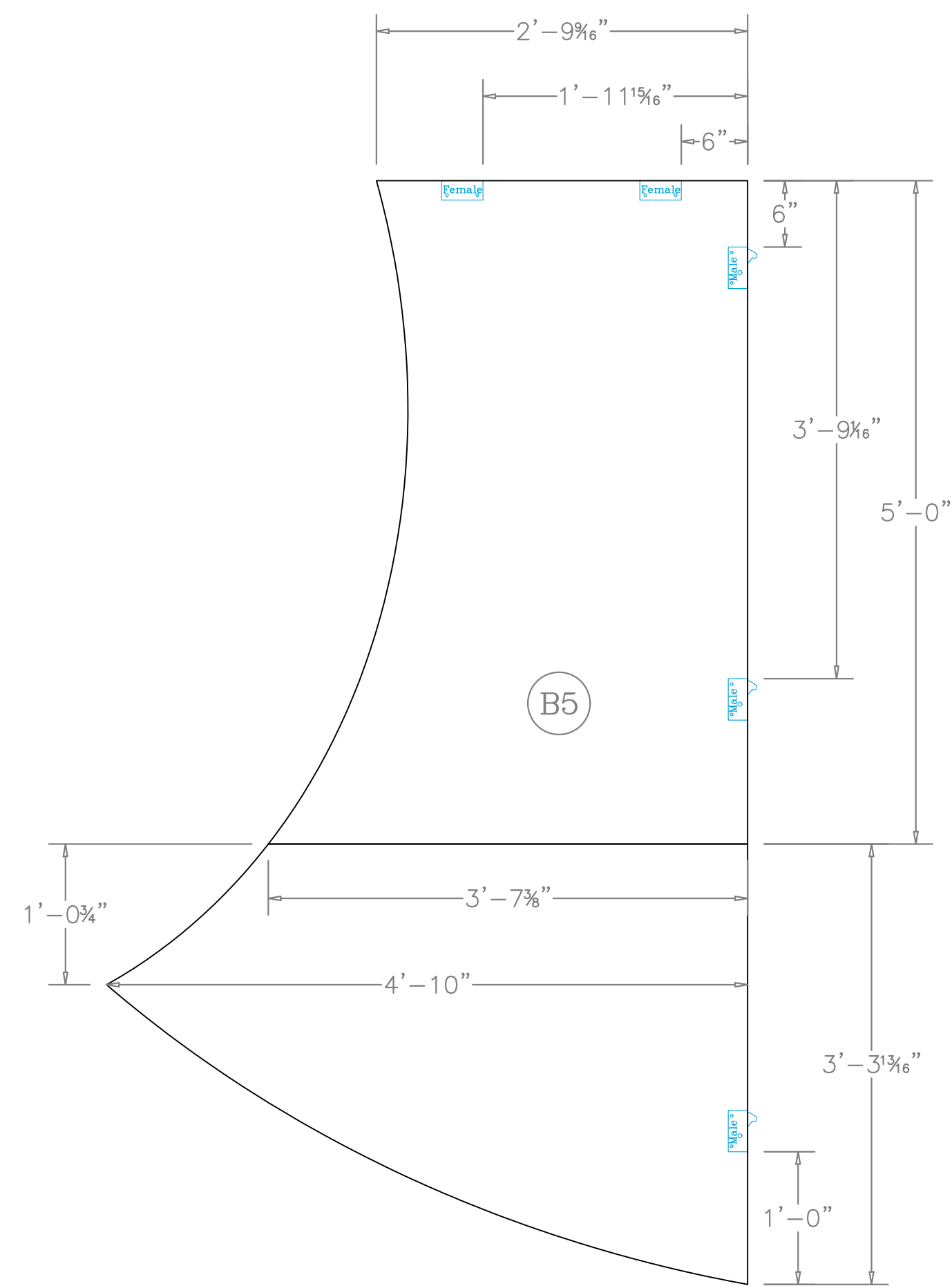

1 Platform B1 Top View  
1" = 1'-0"

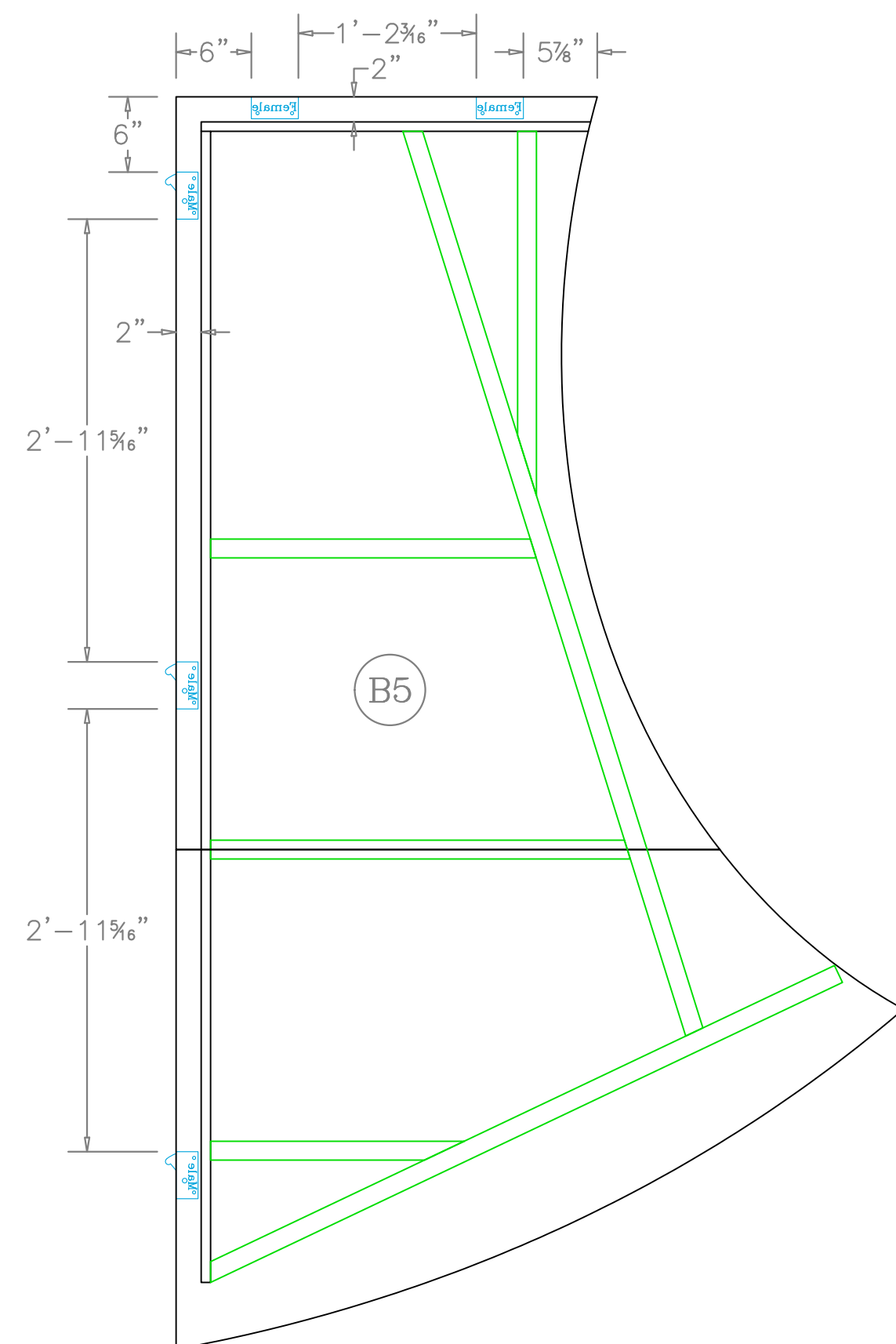

2 Platform B1 Bottom View  
1" = 1'-0"

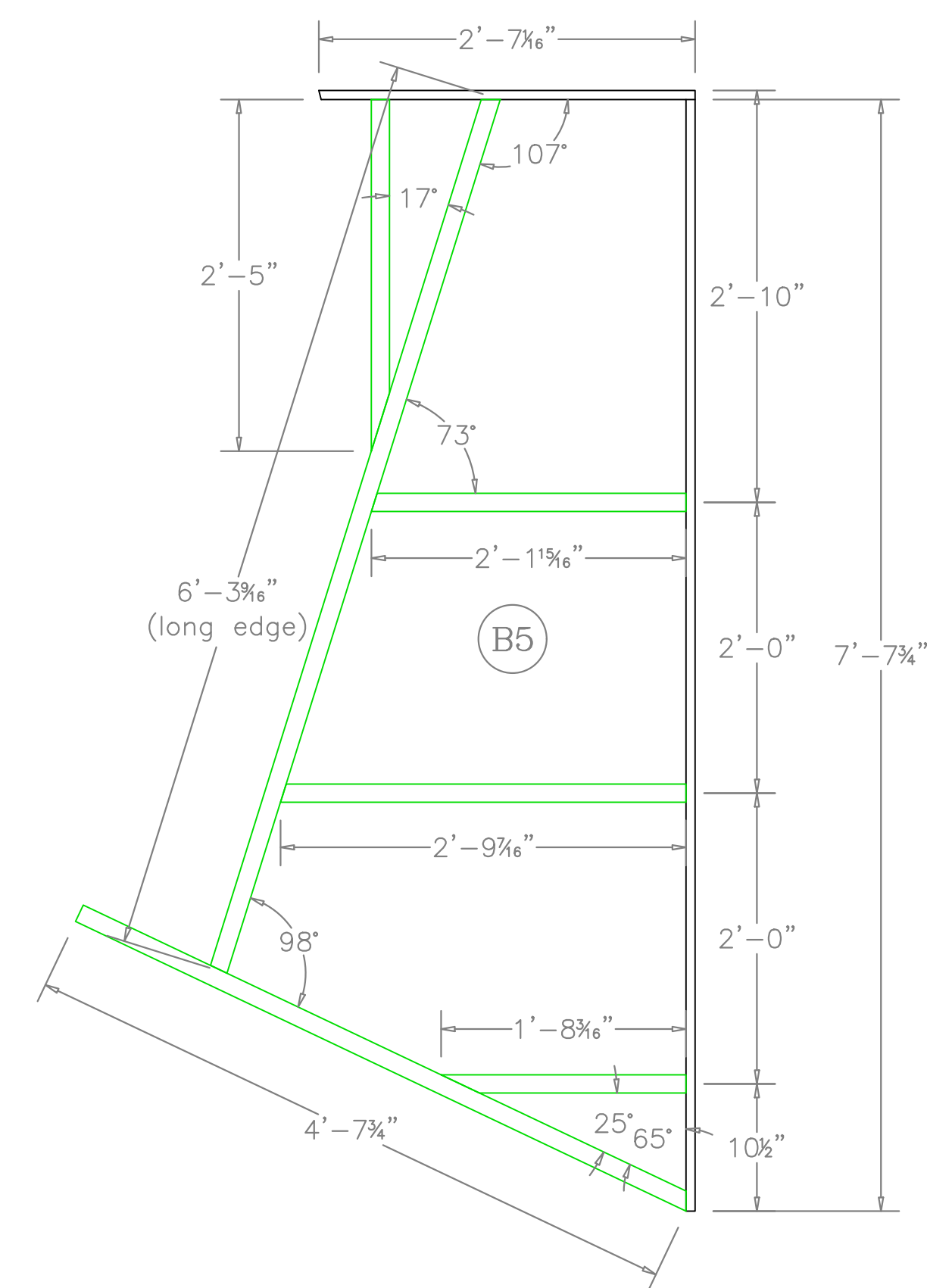

3 Platform B1 Top View - Framing  
1" = 1'-0"

Notes:  
 +Lumber: 2x4 is shown here in green. 3/4" ply in black.  
 +All framing is ripped to 3-1/2" except where otherwise noted. 2x4 can remain at full size.  
 +Curved lids and framing have already been cut from our order with the CNC shop, but some more regularly sized lids may need to be cut still.  
 +Glue and screw all framing. Glue and screw lids to framing.  
 +Fill and sand all screw holes.  
 +Sorry for all the weird shapes

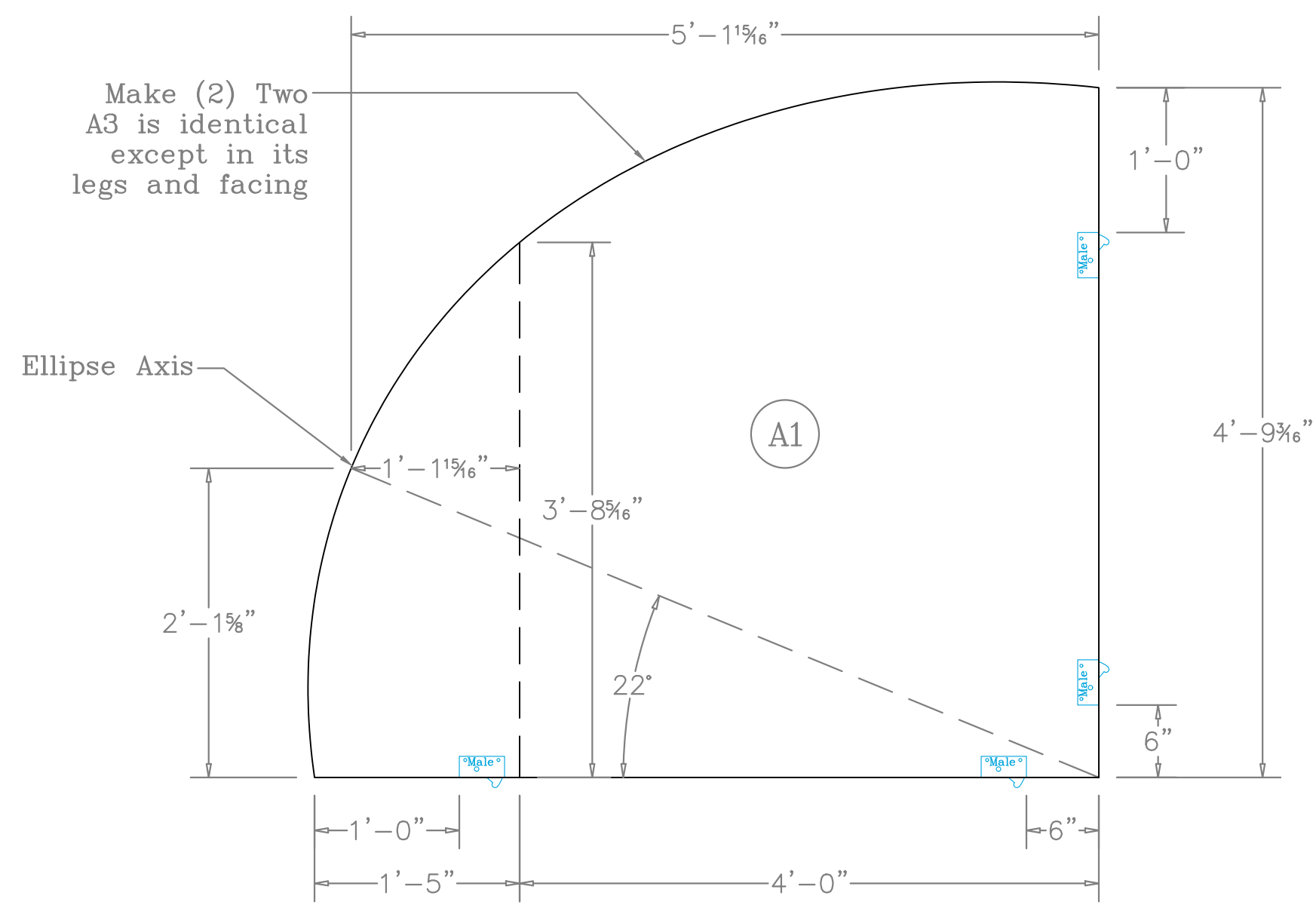

1 Platform B1 Top View  
1" = 1'-0"

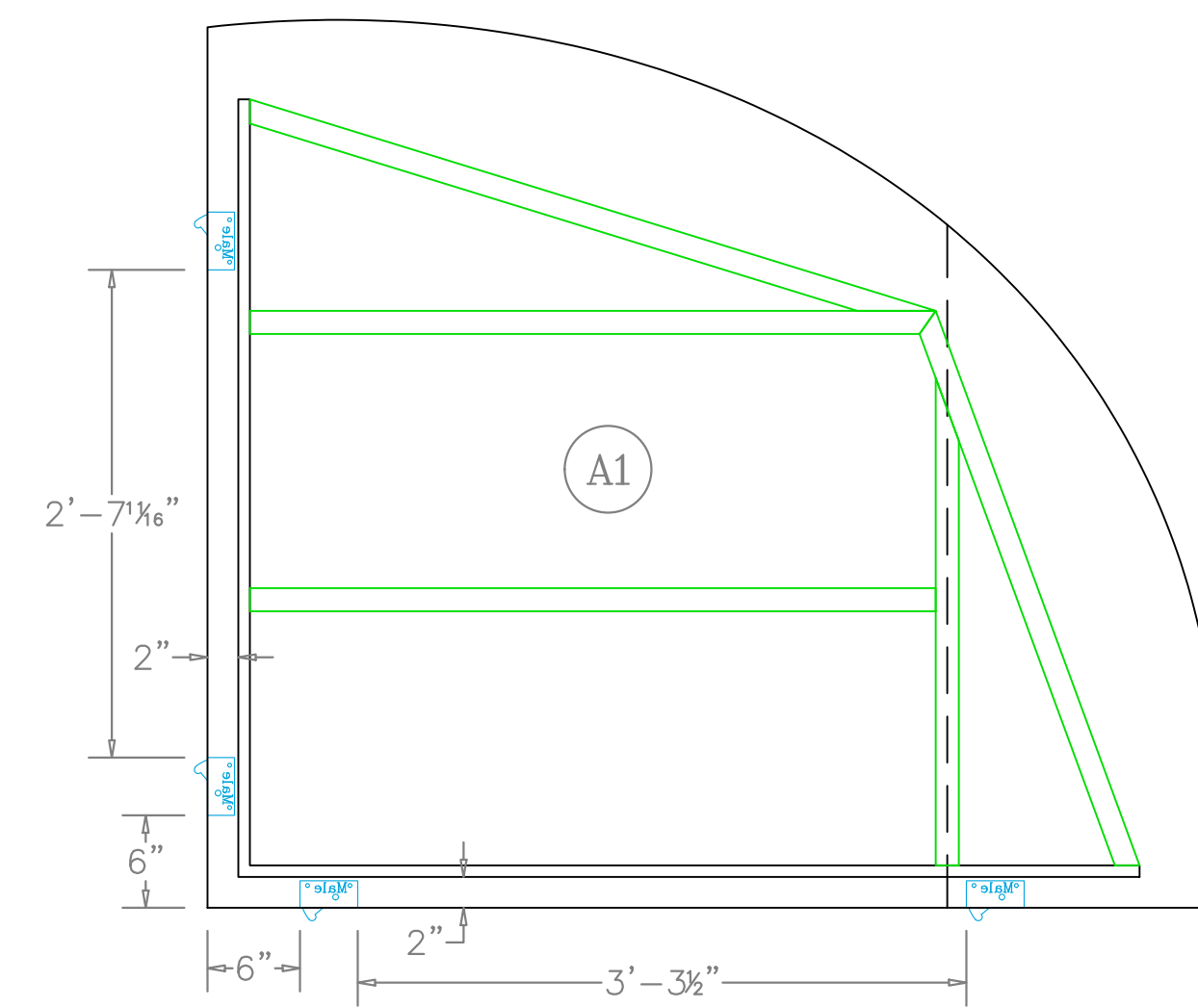

2 Platform B1 Bottom View  
1" = 1'-0"

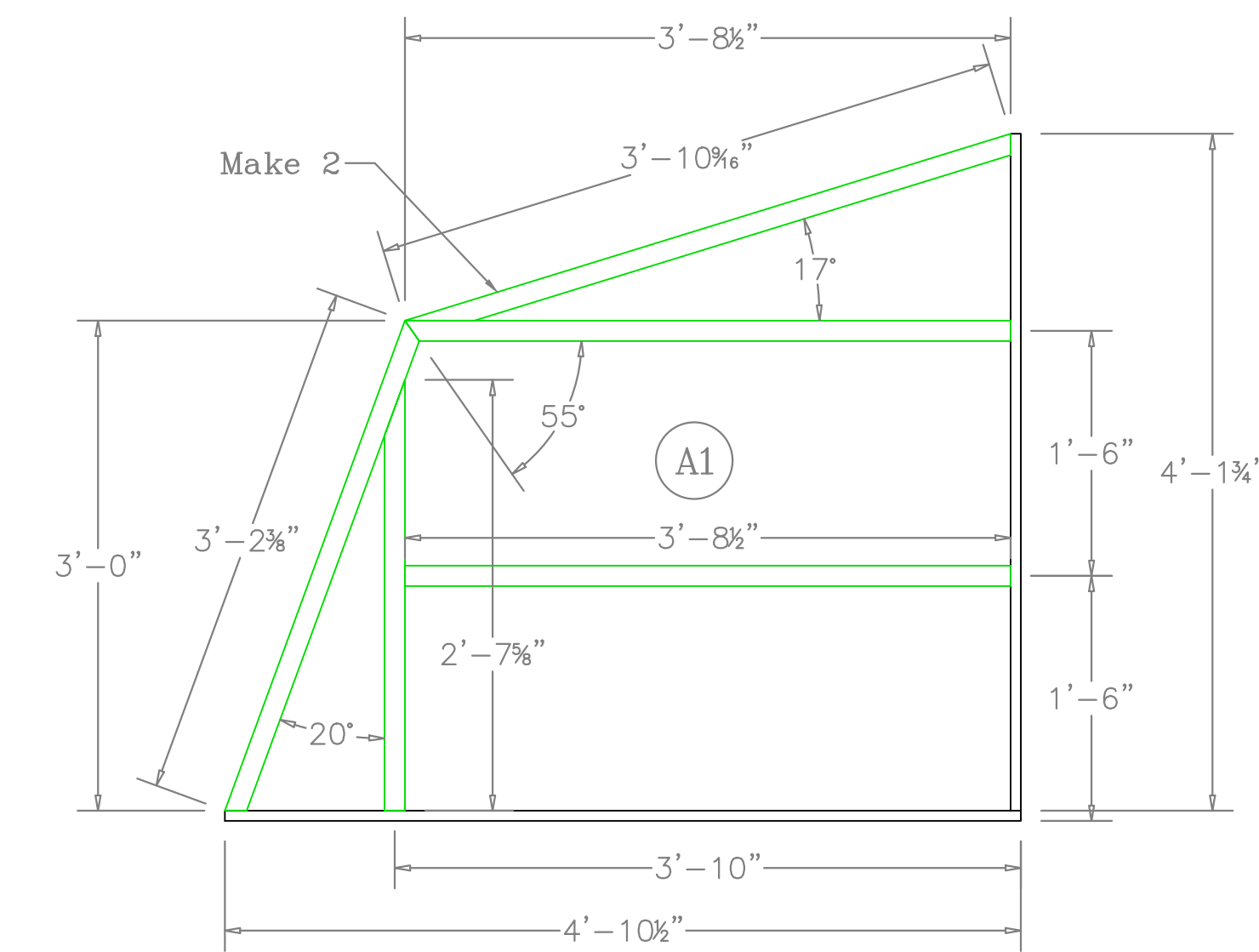

3 Platform B1 Top View - Framing  
1" = 1'-0"

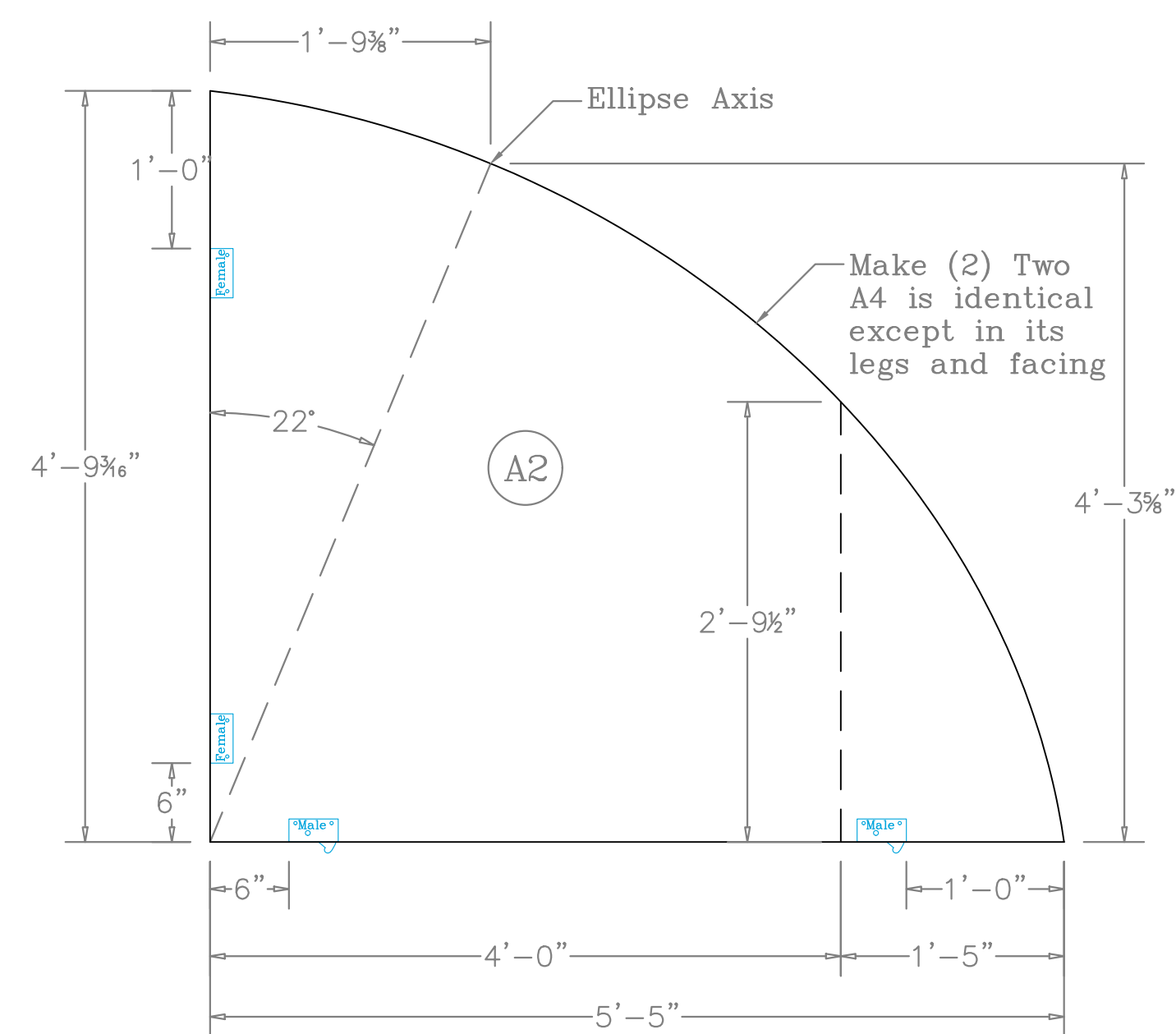

4 Platform B2 Top View  
1" = 1'-0"

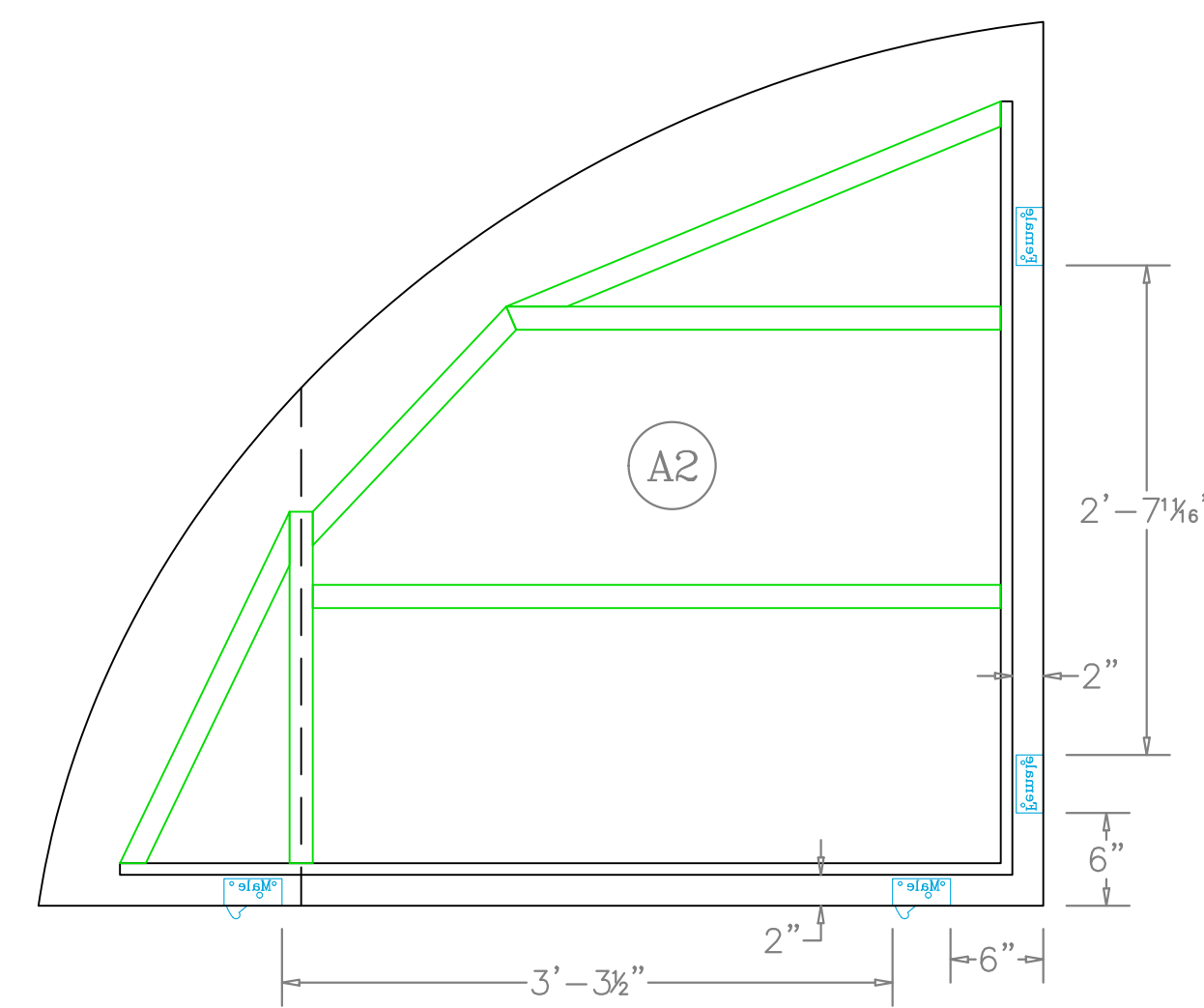

5 Platform B2 Bottom View  
1" = 1'-0"

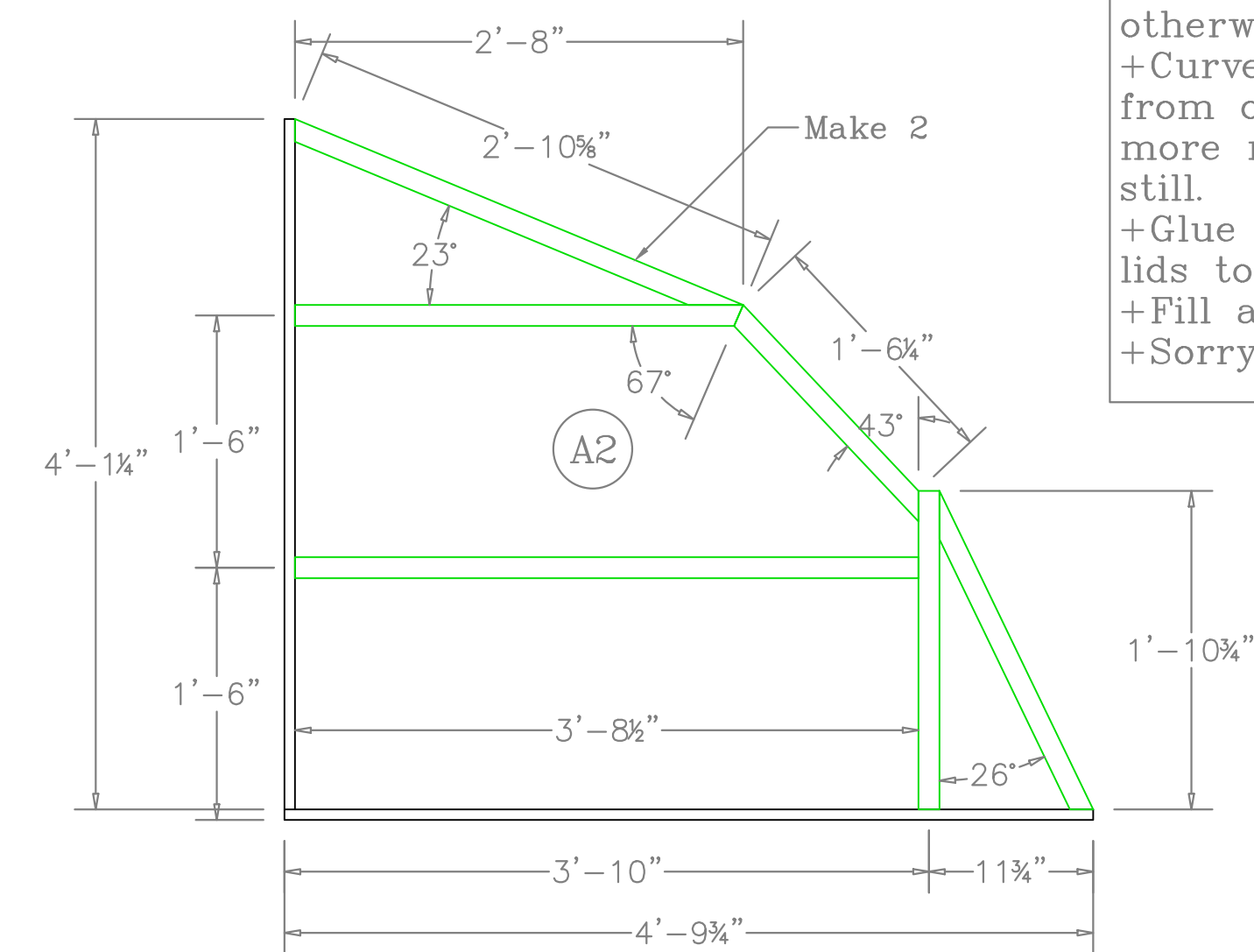

6 Platform B2 Top View - Framing  
1" = 1'-0"

Notes:  
 +Lumber: 2x4 is shown here in green. 3/4" ply in black.  
 +All framing is ripped to 3-1/2" except where otherwise noted. 2x4 can remain at full size.  
 +Curved lids and framing have already been cut from our order with the CNC shop, but some more regularly sized lids may need to be cut still.  
 +Glue and screw all framing. Glue and screw lids to framing.  
 +Fill and sand all screw holes.  
 +Sorry for all the weird shapes

Notes:  
 +Lumber: 2x4 and 2x6 is shown here in green.  $\frac{3}{4}$ " ply in black.  $\frac{1}{4}$  ply in red.  
 +Steel: Shown in Blue. Includes 1.5" sq box tube, 3x3x $\frac{1}{4}$ " angle and other small plates.  
 +Glue and screw all framing. Glue and screw lids to framing.  
 +Fill and sand all screw holes – this entire unit goes glossy black, so pay particular attention to smoothness and consistency

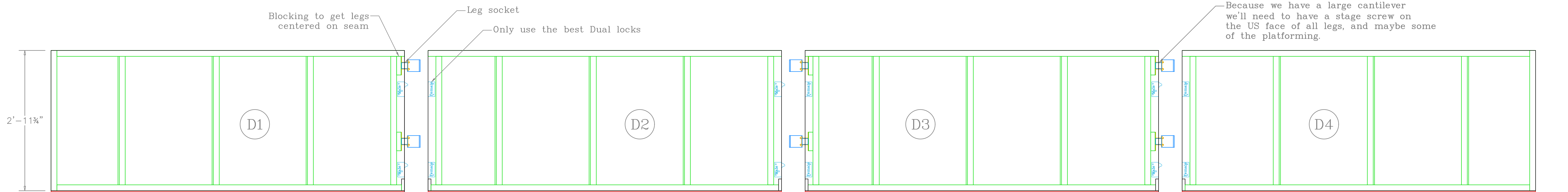

1 Top View – Framing Overview  
 1" = 1'-0"

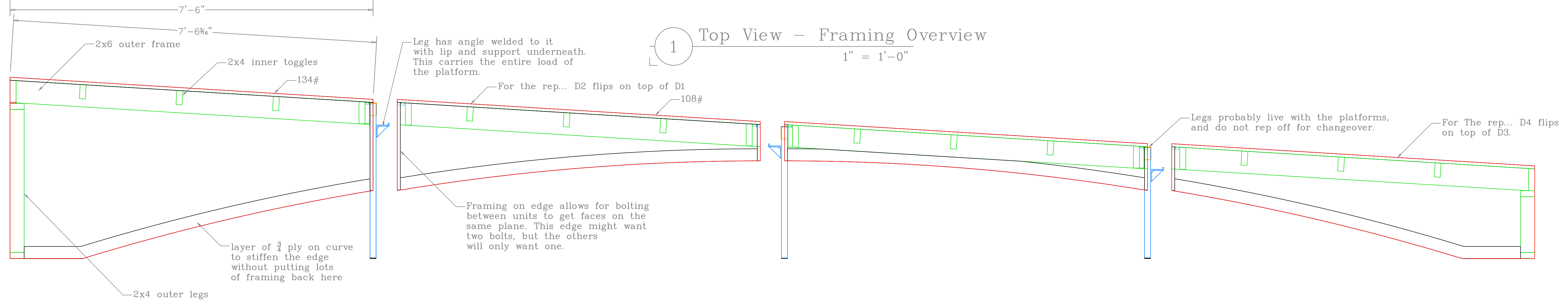

2 Front View – Framing Overview  
 1" = 1'-0"

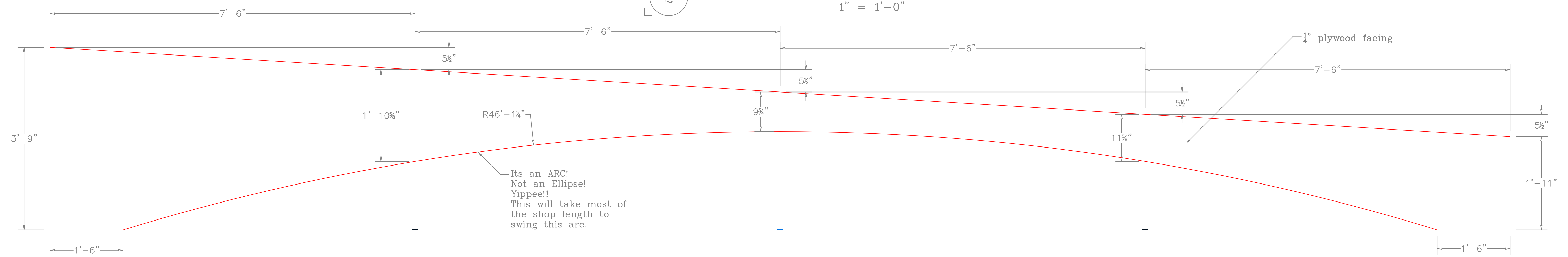

1 Finished Front View  
 1" = 1'-0"

14	Bridge Overview	American Players Theatre 2023	Scale: 1" = 1'-0"	Director: Laura Rook	TD: Bill Duwell.
	Production: Once Upon a Bridge		Date: 5/10/2023	Scenic Design: Lawrence Moten	ATD: Doug Dion

All Lids are identical.  
High and low end of the rake  
have edges beveled at 3 degrees

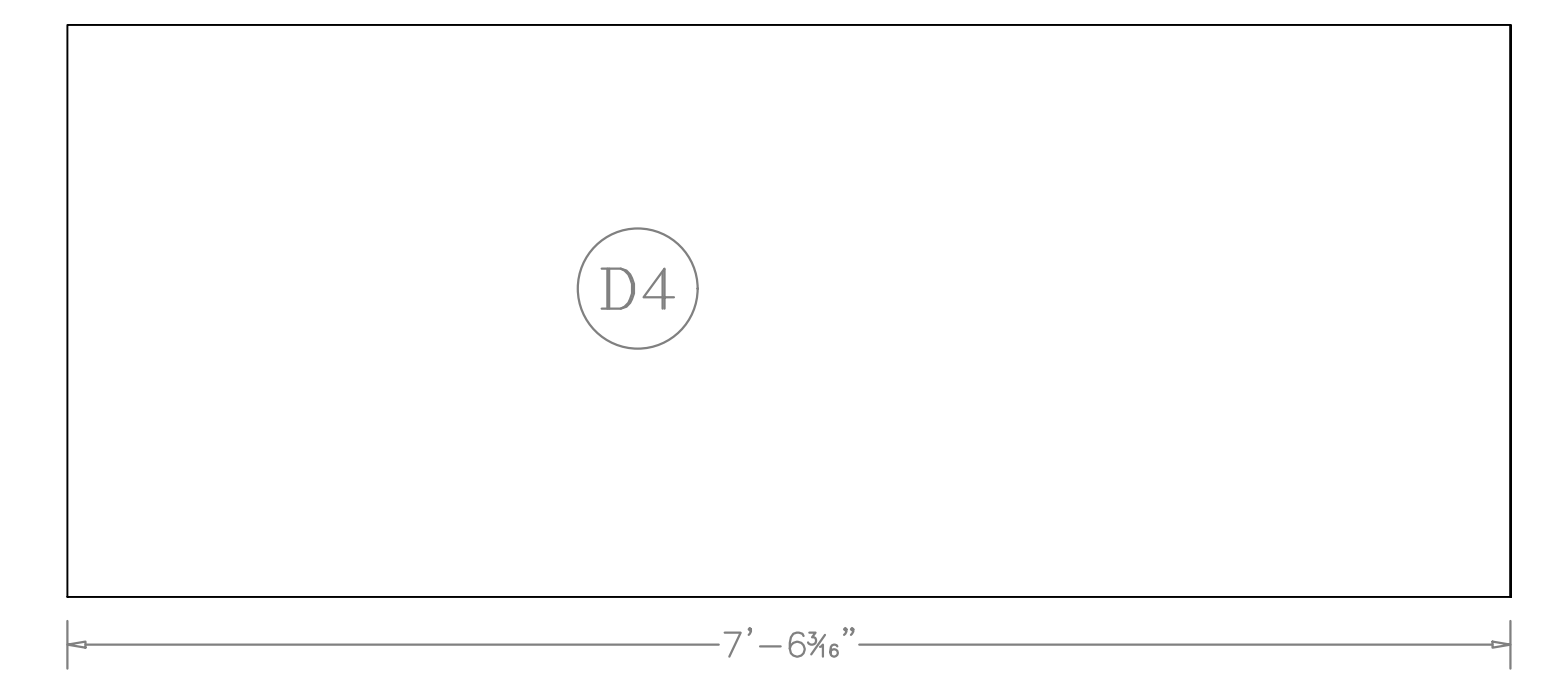
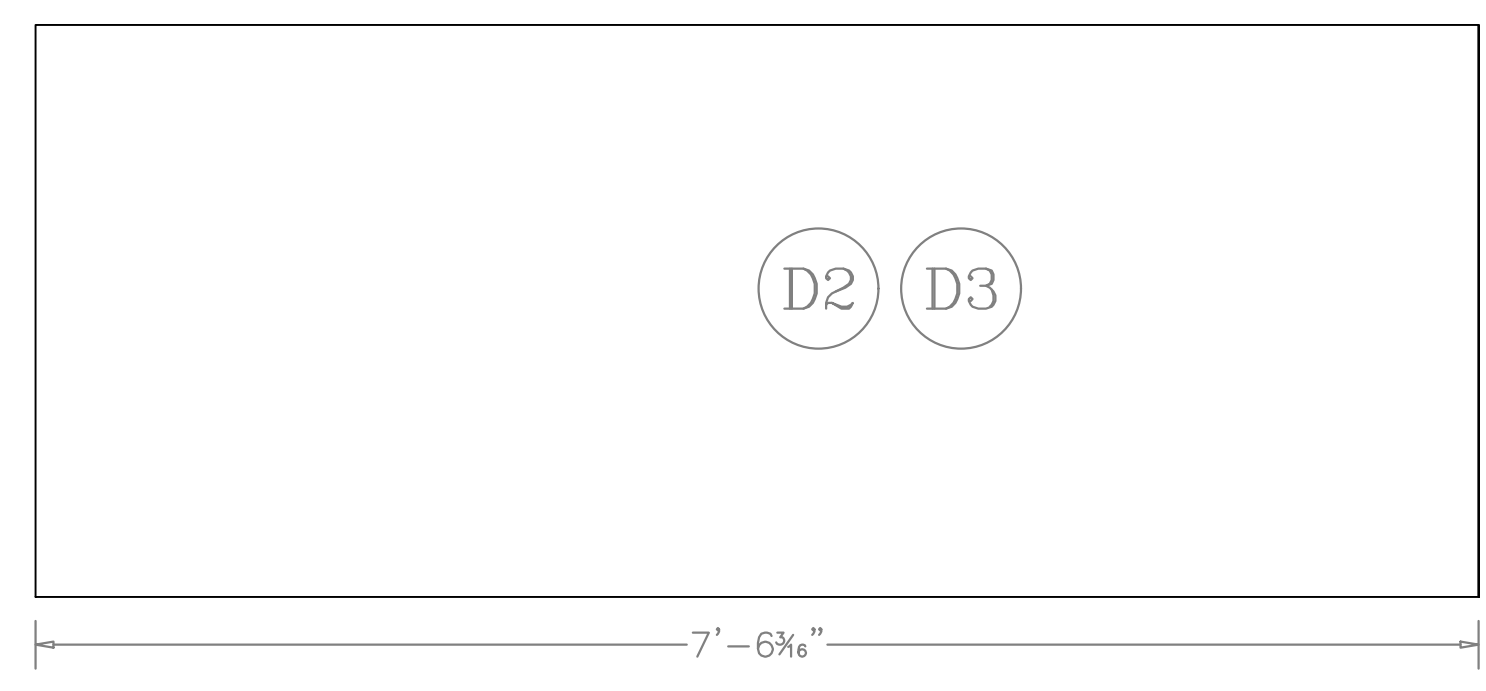
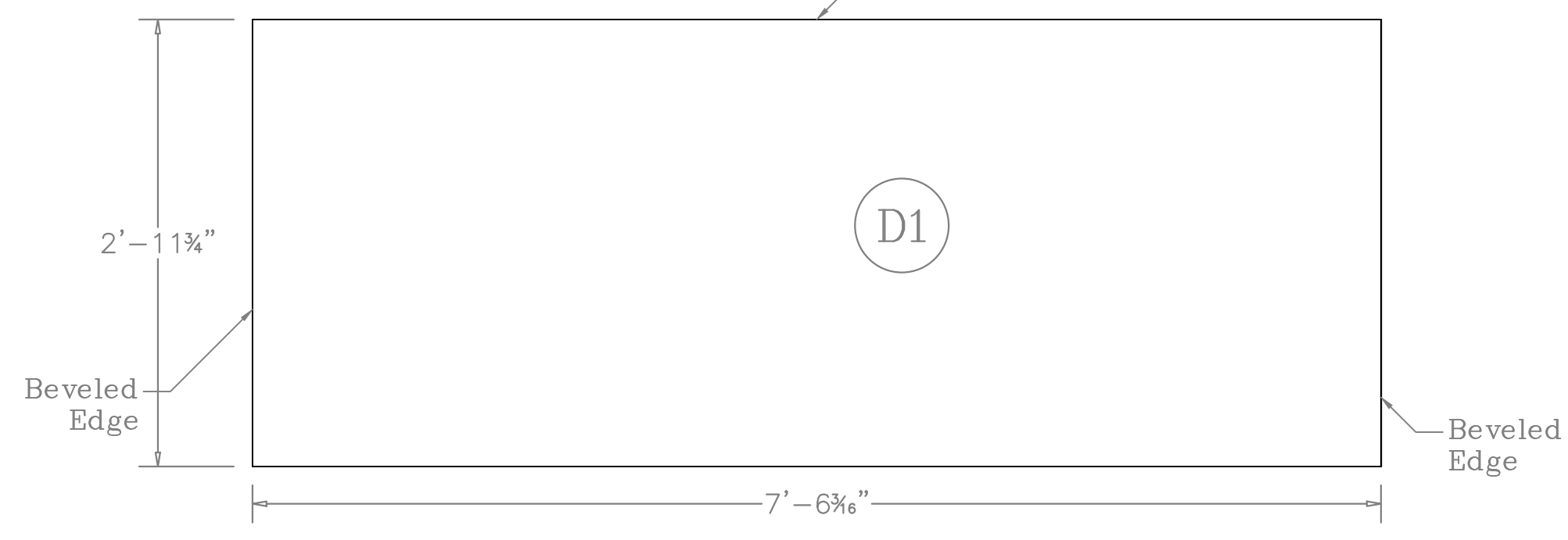

1 Lid - D1  
1" = 1'-0"

2 Lid - D2  
1" = 1'-0"

3 Lid - D4  
1" = 1'-0"

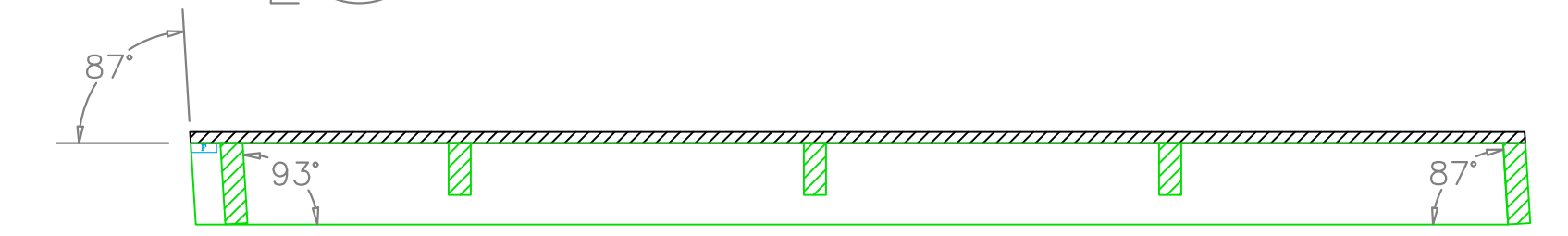
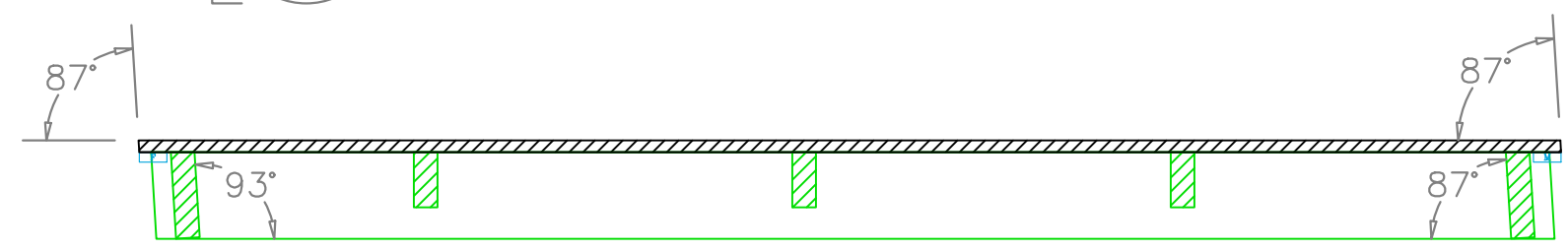
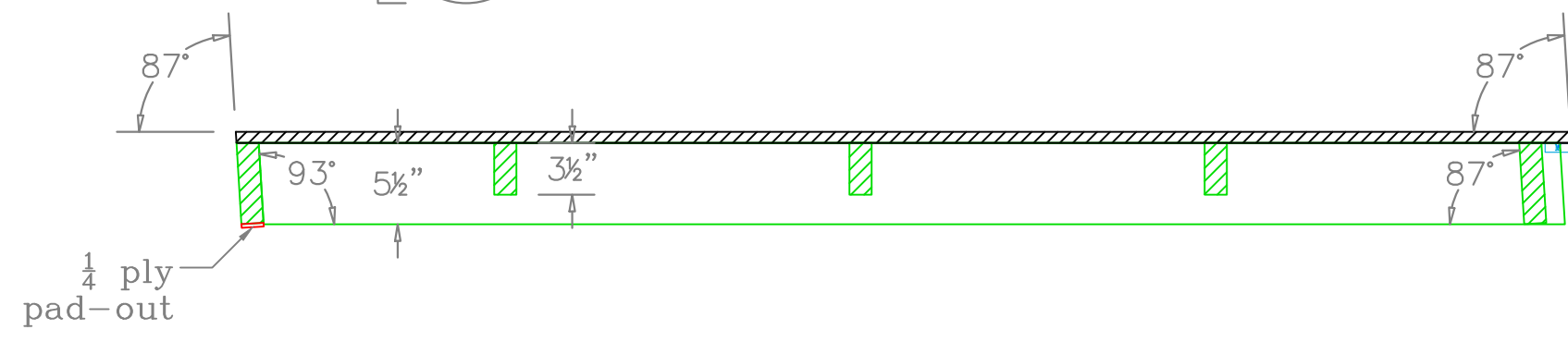

4 Section - D1  
1" = 1'-0"

5 Section D2 & D3  
1" = 1'-0"

6 Section D4  
1" = 1'-0"

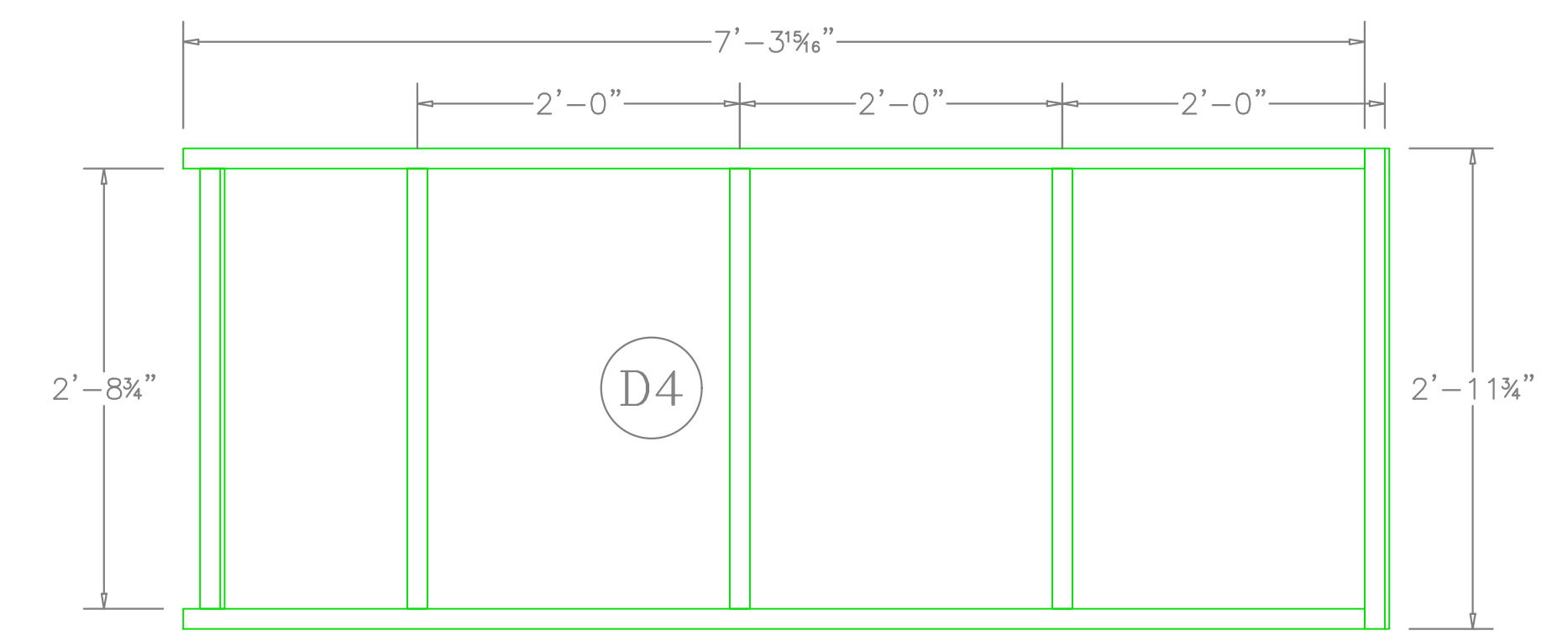
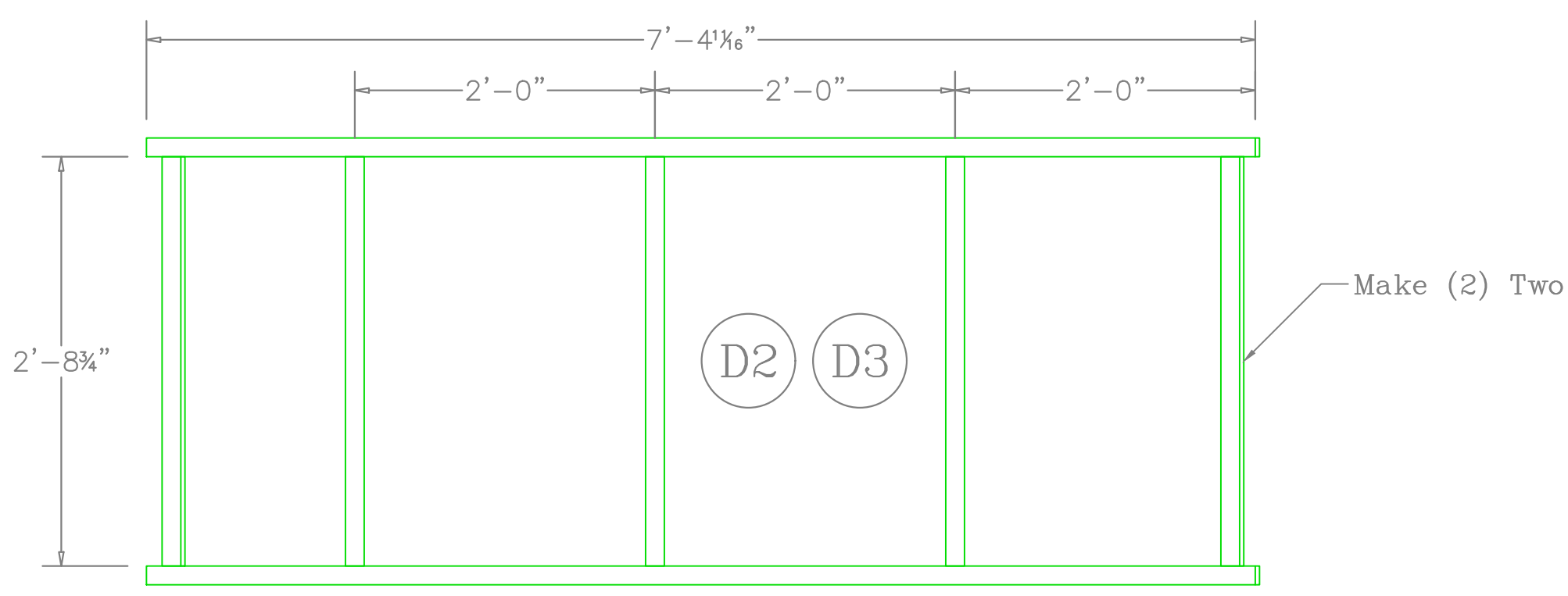
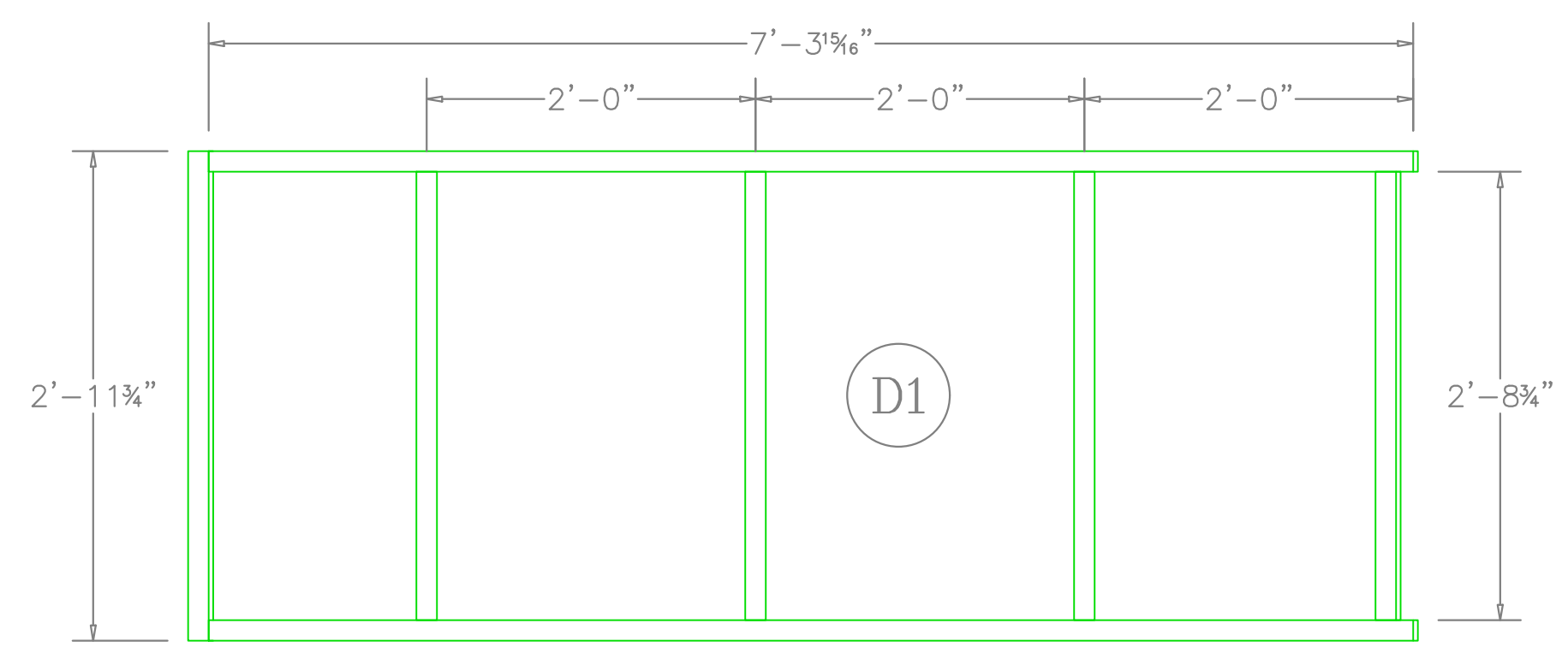

7 Aligned View - Framing - D1  
1" = 1'-0"

8 Aligned View - Framing - D2 & D3  
1" = 1'-0"

9 Aligned View - Framing - D4  
1" = 1'-0"

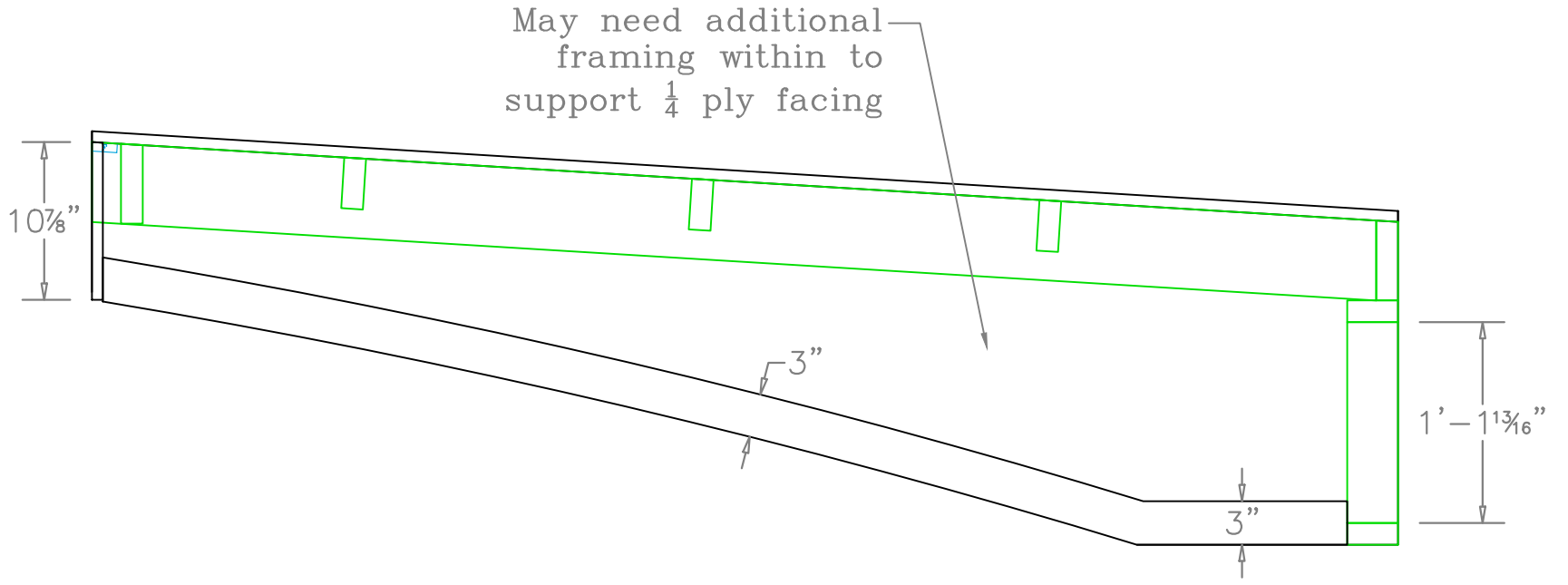
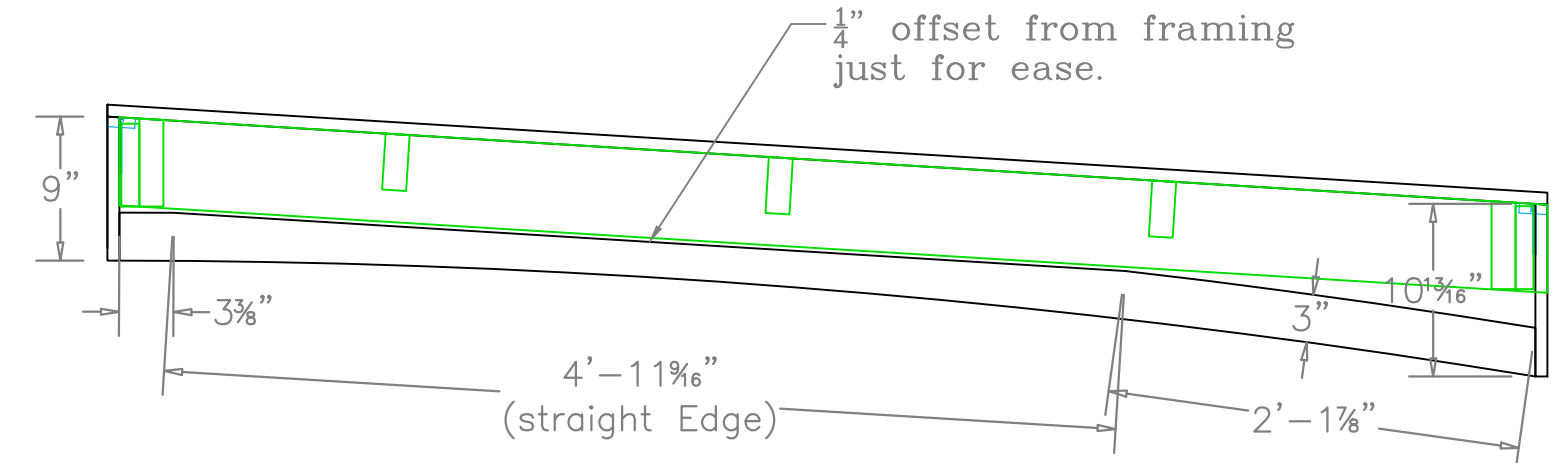
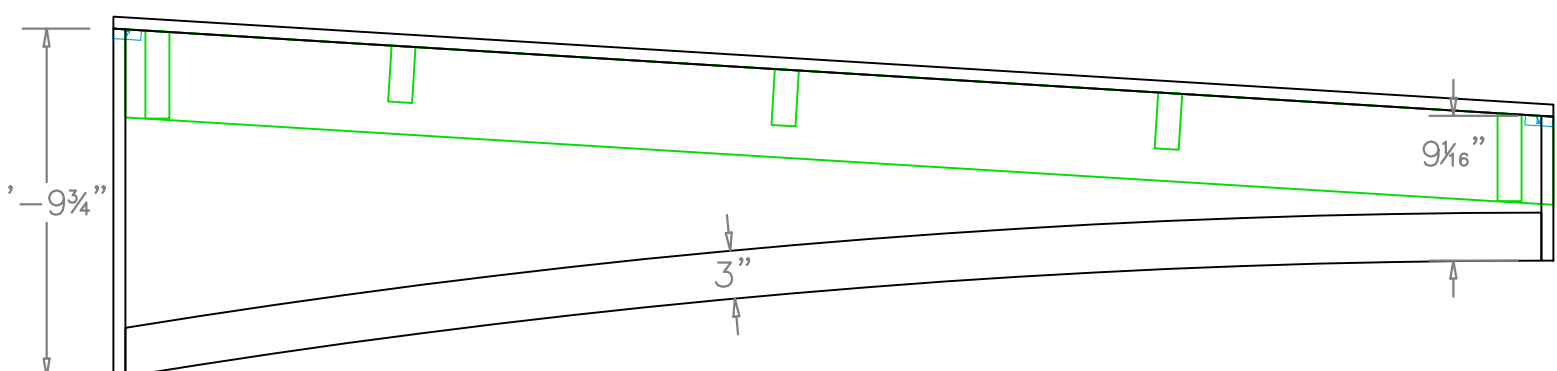
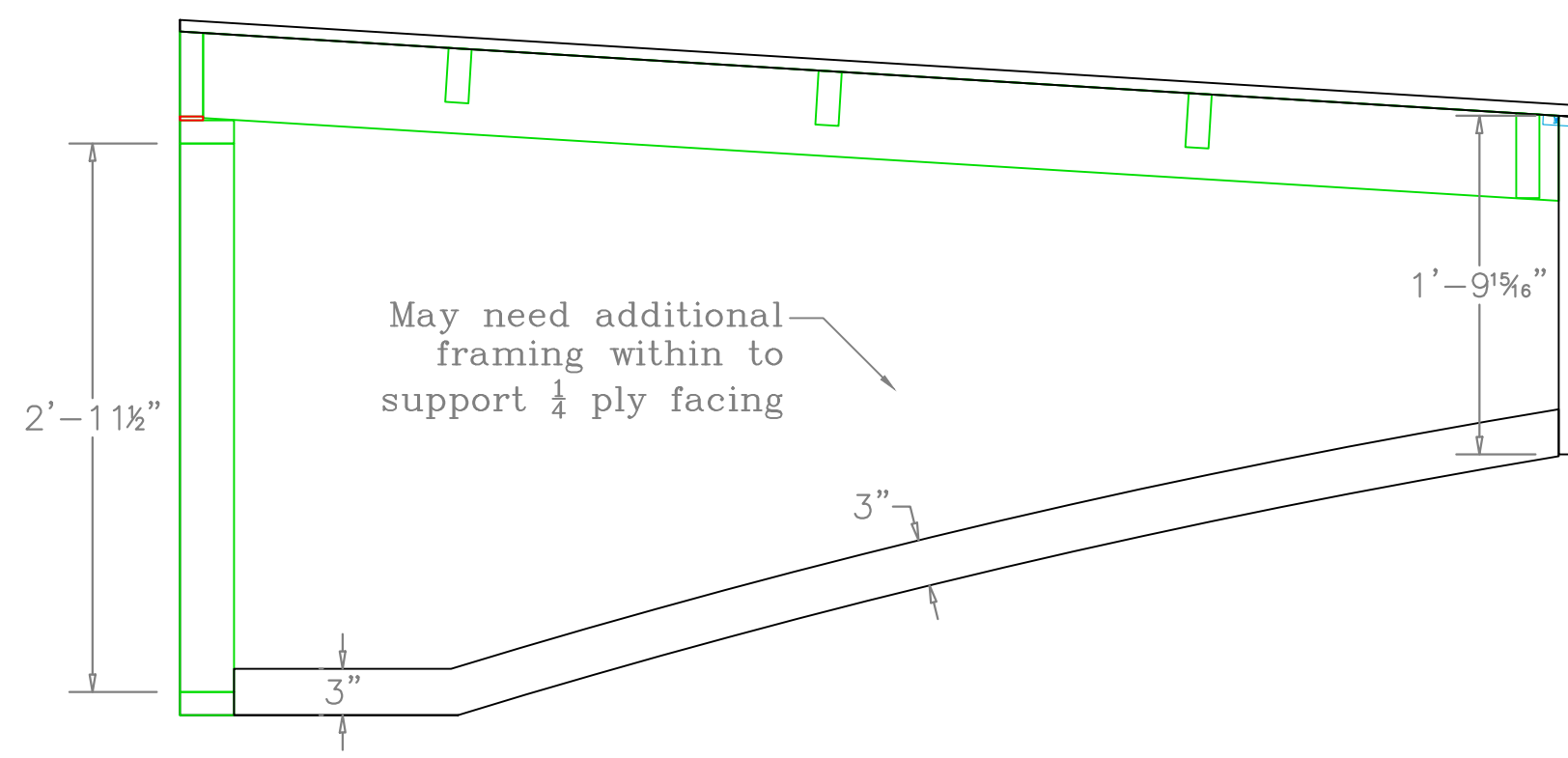

10 Front View - Framing - D1  
1" = 1'-0"

11 Front View - Framing - D2  
1" = 1'-0"

12 Front View - Framing - D3  
1" = 1'-0"

13 Front View - Framing - D4  
1" = 1'-0"

15	Bridge Framing	American Players Theatre 2023	Scale: 1" = 1'-0"	Director: Laura Rook	TD: Bill Duwell.
	Production: Once Upon a Bridge		Date: 5/10/2023	Scenic Design: Lawrence Moten	ATD: Doug Dion



Notes:  
 +Make two of each of these.  
 +May want to wait until we rig in the space to weld on the brackets. Maybe we also tack them in place when we're in touchstone? We should pre-cut these legs but may not get the correct height the first try.  
 +Will need to make more leg sockets, so lets just make at least six new double nut, flat mount sockets.

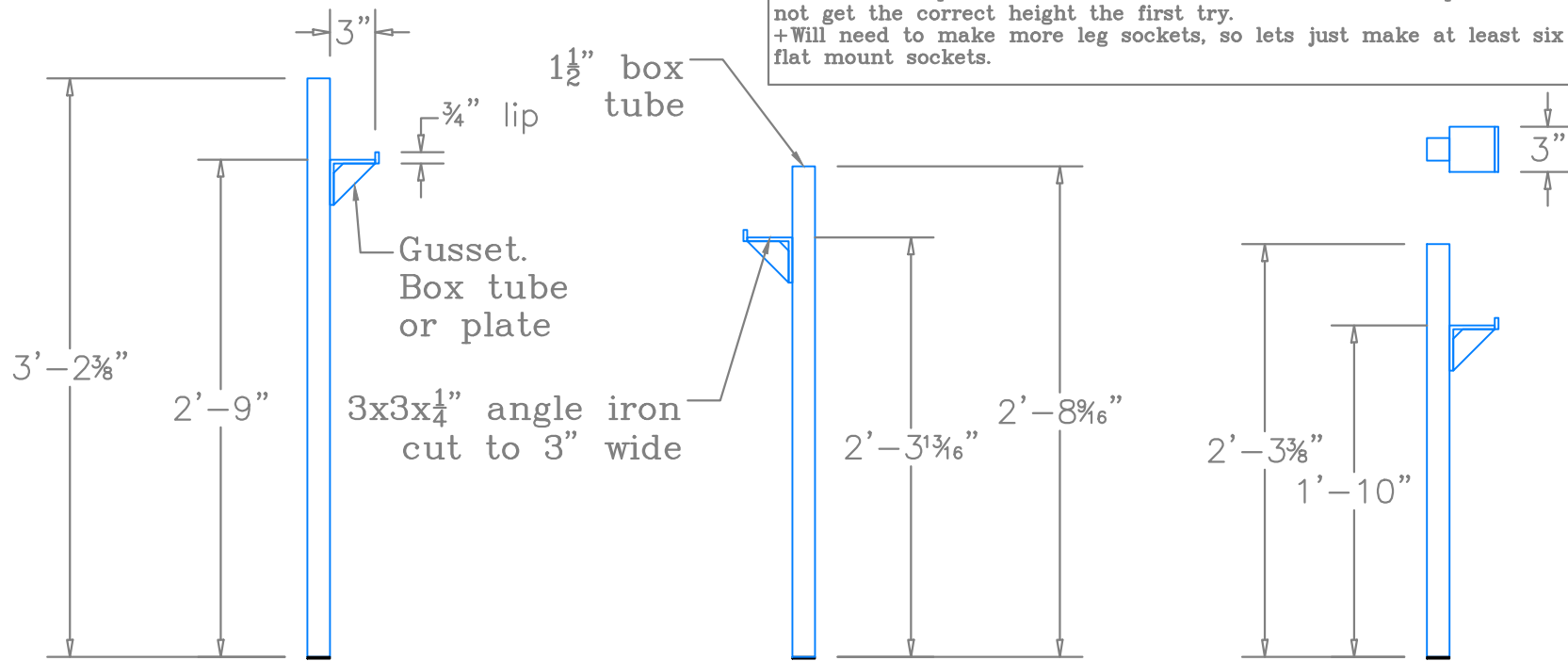

① Legs - Seam D1-2  
 1" = 1'-0"

② Legs - Seam D2-3  
 1" = 1'-0"

③ Legs - Seam D3-4  
 1" = 1'-0"

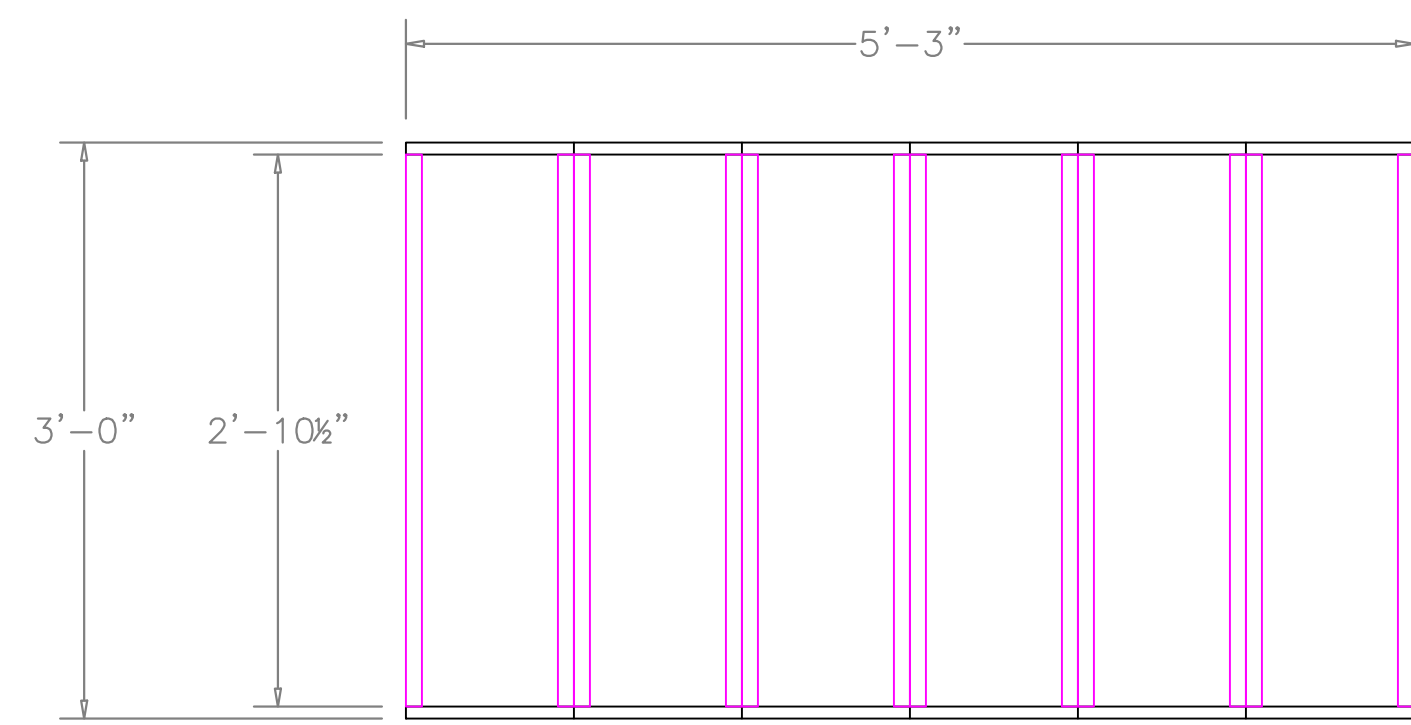

1 SR Stair - Top View - No Treads  
1" = 1'-0"

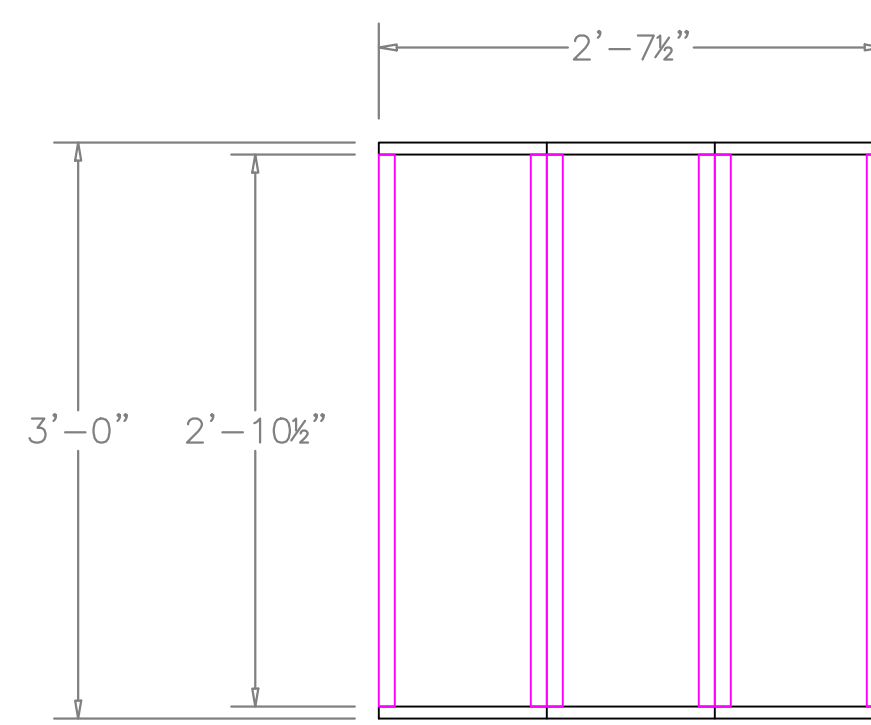

1 SL Stair - Top View - No Treads  
1" = 1'-0"

Notes:  
 +Lumber: 3/4" ply in black. 1" plywood shown in pink.  
 +Despite being escape stairs these are in view of the audience and their DS edge should look clean. Fill any screws/staples, and clean any plywood edges here as well.  
 +There is enough scrap 1" plywood to use for the treads here, but if you need/want to build these differently lets discuss how that changes framing.  
 +Fill and sand all screw holes. Remove dust for paint.  
 +Round over/smooth edges for handling.

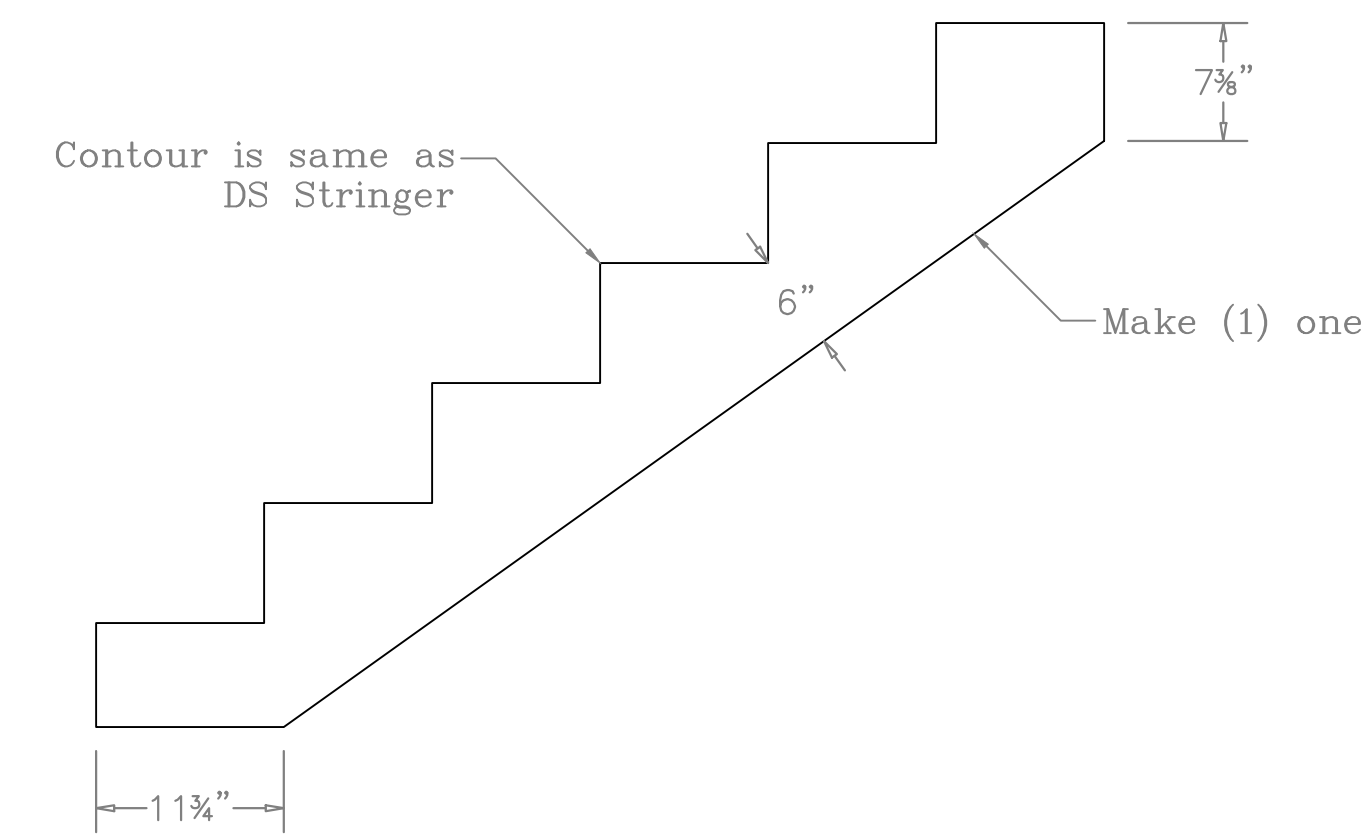
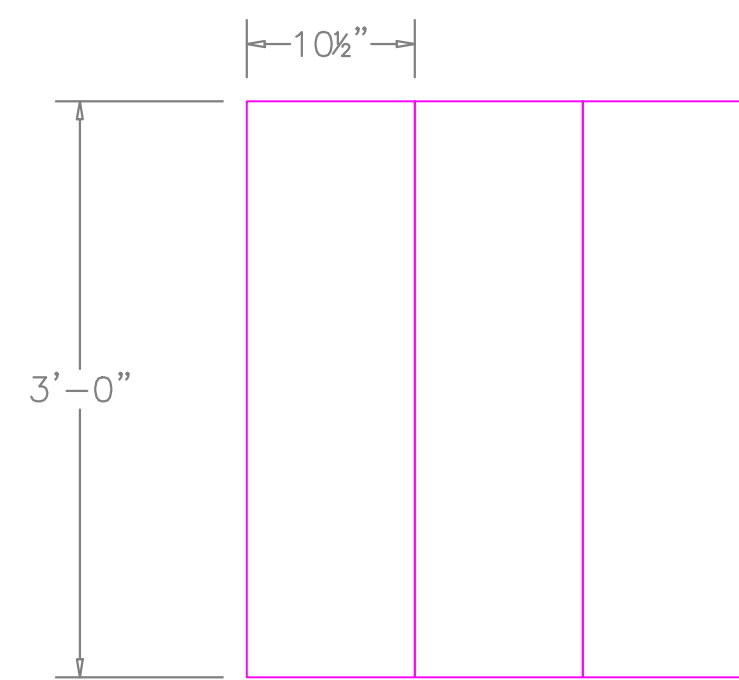
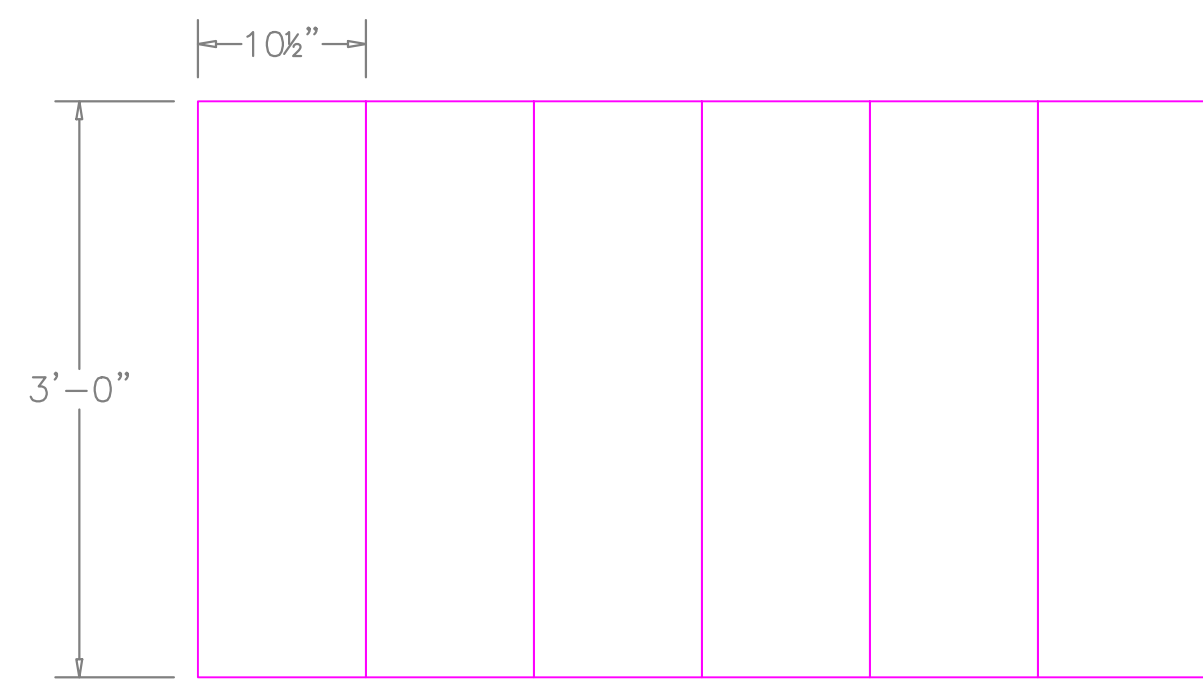

1 SR Stair US Stringer  
1" = 1'-0"

1 SR Stair Top View  
1" = 1'-0"

1 SL Stair Top View  
1" = 1'-0"

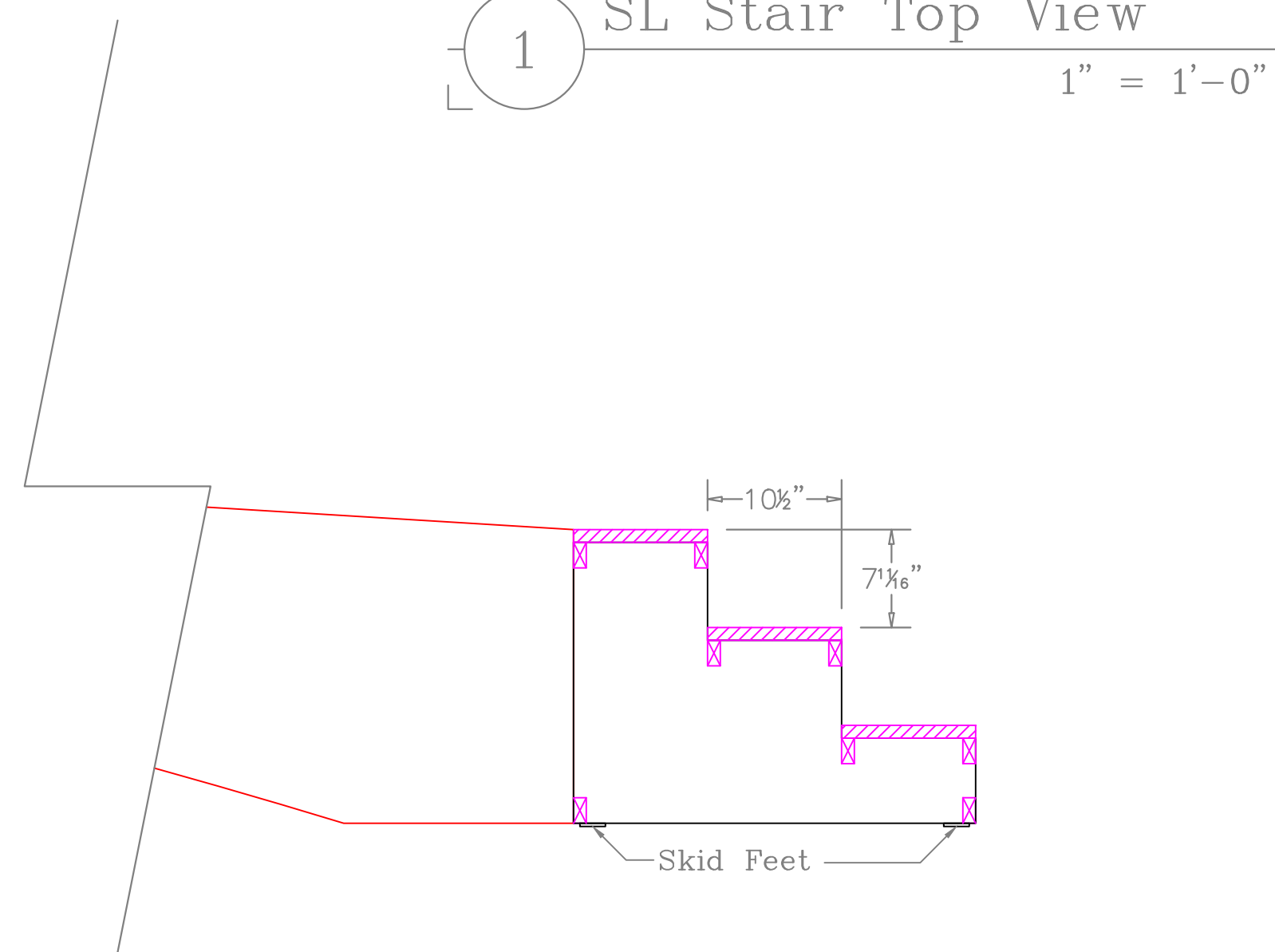
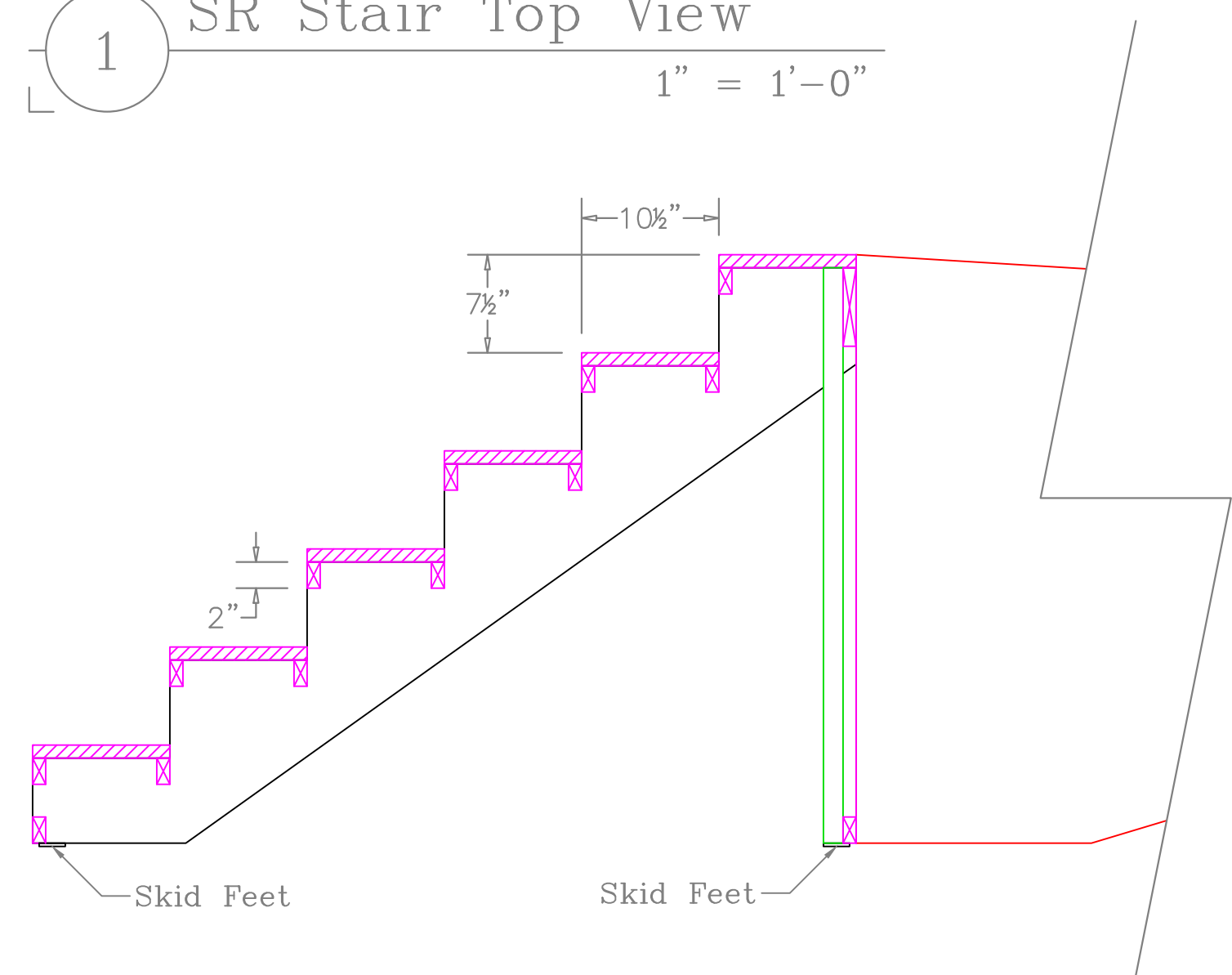
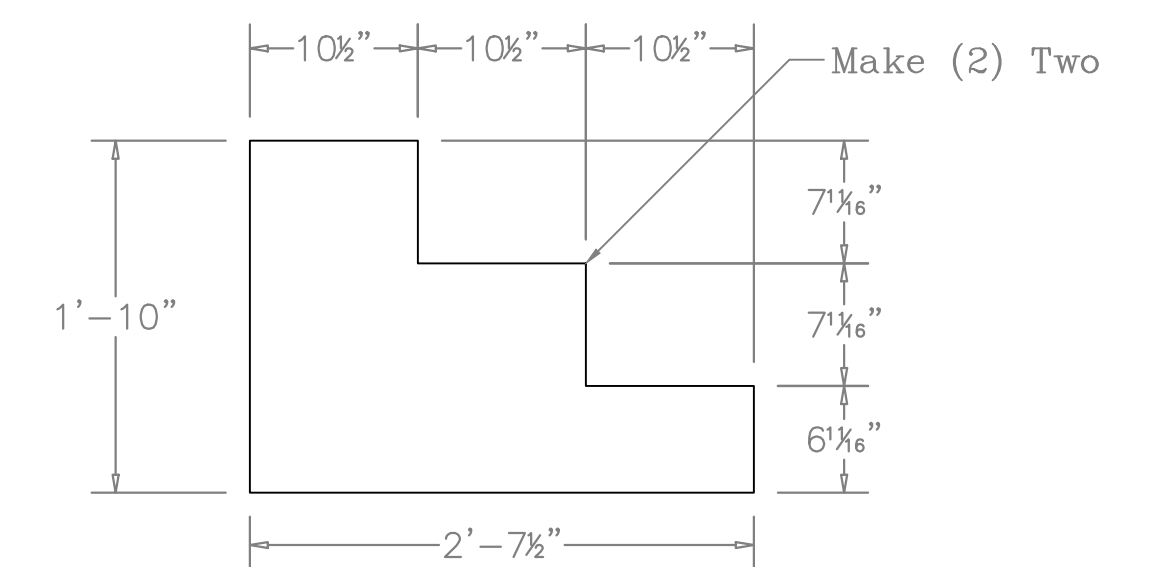
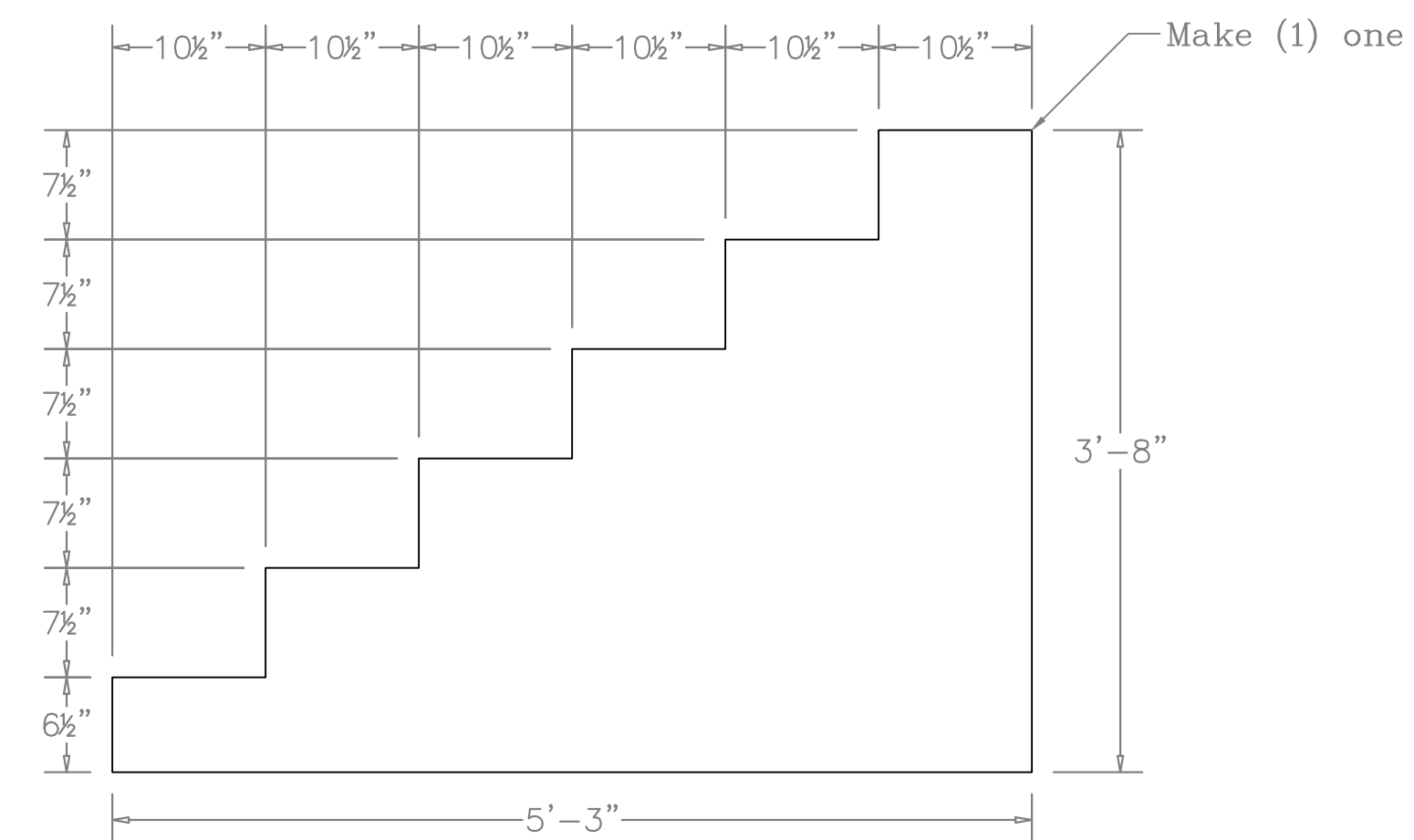

1 SR Stair Section  
1" = 1'-0"

1 SL Stair Section  
1" = 1'-0"

1 SR DS Stair Stringer/Facing  
1" = 1'-0"

1 SR Stair Stringer/Facing  
1" = 1'-0"